

Model: SISCO-DPM-DY220

Technical specifications:

1. Analog inputs

Analog input uses 20 bit AD chip, sampling rate 50 times / sec, the accuracy of 0.2%

Display range -9999~19999

The maximum number of divisions 50000

Supply voltage 10V, 100mA



2. Switch output

3 relay or OC output. Relay contact 250V/1A OC, optional AC output driver 100mA/48V.

3. Transmitting Output

Output 4-20mA, 12bit precision, driving 500 ohm load. Optional function.

4. Communication port

485 port, can perform modbus RTU and active upload protocol. This function is optional.

5. Simple comparison output

Function Description: the 3 output of the indicator can be set to be greater than or less than the comparison. When the measurement value is greater than the upper limit, the output is valid, and the output is invalid when the measurement value is less than the upper limit. When the output is set to be less than the comparison, the output is effective when the measurement value is less than the lower limit, and when the measurement value is higher than the lower bound, the output is invalid. See diagram for details.

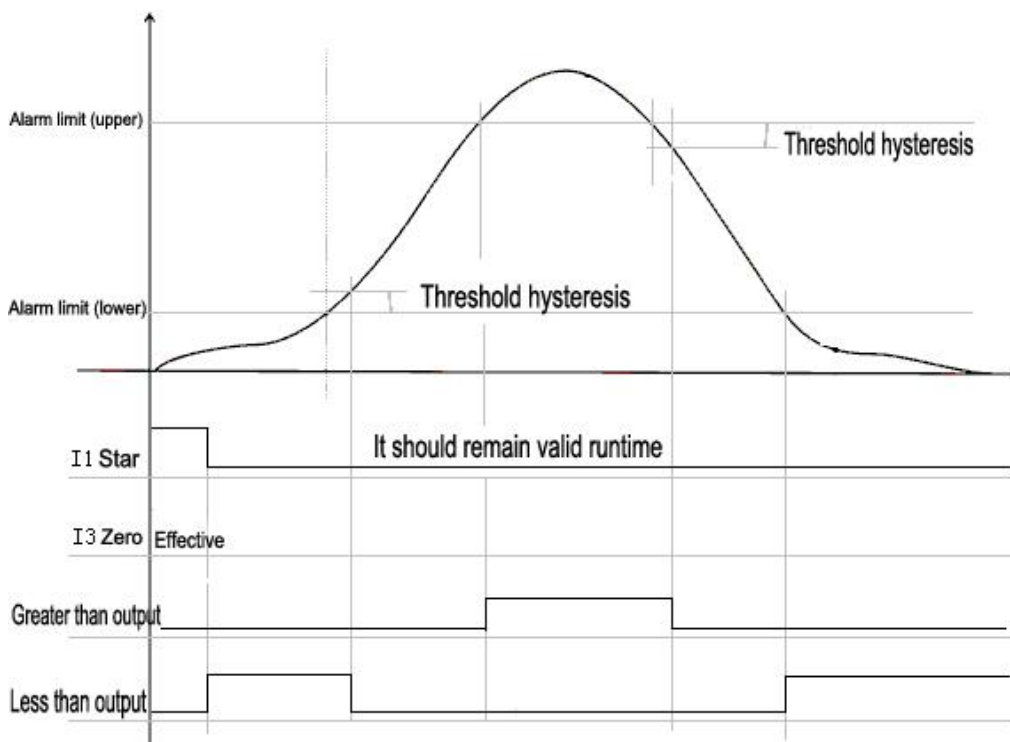

Working Mode

1. 210A peak mode (Enter 01 into Ed-20)

When 210A is displayed on start interface of the controller, it works in peak mode. Press the third button, and when the interface is "AXXX", it is in peak status.

Description: When the measured value reaches the trigger threshold, the peak judgment will be started. When

the measured value is less than the trigger threshold, the peak judgment is over, and alarm delay will automatic reset.

Peak alarm:

Peak value \geq alarm upper limit, the switching value 01 is valid.

Peak value \leq alarm lower limit, the switching value 02 is valid.

Alarm lower limit \leq peak value \leq alarm upper limit, the switching value 03 is valid.

2. 220 normal mode (Enter 09 into Ed-20)

When 220 is displayed on start interface of the controller, it works in normal mode, which has the comparison output function for displaying real-time weight and switching value.

Description: The three outputs of the controller can be set as greater-than comparison or less-than comparison.

Greater-than comparison:

Measured value \geq upper limit, the output is valid.

Measured value \leq lower limit, the output is invalid.

Less-than comparison:

Measured value \leq lower limit, the output is valid.

Measured value \geq upper limit, the output is invalid.

3. 230 initiating mode (Enter 10 into Ed-20)

When 230 is displayed on start interface of the controller, it works in initiating mode.

Description: Close and open the start terminal for 1 second before disconnecting, OUT 1 and OUT 2 lights are on, switching value 1 and switch value 2 are closed. When the displayed weight reaches the first comparison limit switching value 1, OUT 1 light is off. When the displayed weight reaches the second comparison limit switching value, OUT 2 light is off. Operate it again, if no start terminal is opened during the period, the switching value has no output.

Operation instructions

1. Panel



2. Terminal diagram

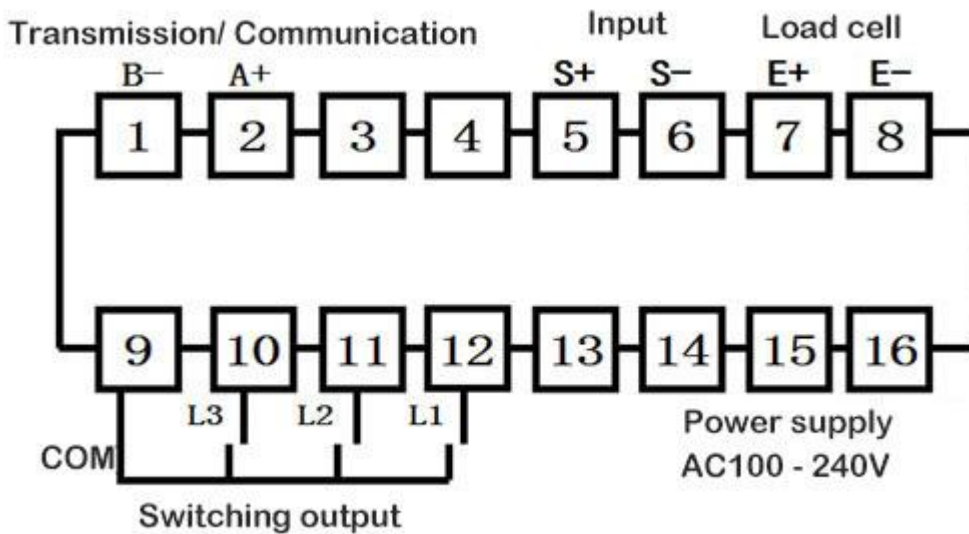

3. Menu structure

- 3.1: Parameter modification. Standby status, long press [k1]+ enter password, password write 200, enter the advanced parameter password to write 205.
- 3.2: Weight calibration. Standby status, long press [k2]+ password to enter, password is written 200.
- 3.3: Press Zero to clear. Standby status, long press [k4], when the measured value is less than zero range, clearing completed.
- 3.4: Restore factory settings. According to 3.1 to modify the parameters (but need to use special password when input password) to switch to the 41st parameter, input digital numbers between 11-19, and then press [k1] to switch next parameter, and then press[k2] to exit the way to restore the instrument parameters 1-9 initial state.
- 3.5: Data backup. Method of operation same as 3.4, enter the number 20 (see table).

Parameter specification

The upper display parameters, lower display "Ed-11"

Symbol	The way 1-6	Range of values	
Ed-01	First comparison limit	-9999~19999	
Ed-02	Second comparison limit	-9999~19999	
Ed-03	Third comparison limit	-9999~19999	
Ed-04	Compare mode	0-111	
Ed-05	Hysteresis 1	0-1000	
Ed-06	Hysteresis 2	0-1000	
Ed-07	Hysteresis 3	0-10000	
Ed-08	Repeated detection times	1-99	
Ed-09	Alarm delay	0-120.0s	
Ed-10	Zero tracking	0-10d	
Ed-11	Digital filtering	1-100	
Ed-12	Debounce filter	0-100	
Ed-13	Display refresh rate	1-20(10)	
Ed-14	Display units	1-t 2-kN 3-kg 4-lb 5-g	

Ed-15	Decimal point	0-5	
Ed-16	Calibration unit	1-t 2-kN 3-kg 4-lb 5-g	
Ed-17	Calibration decimal point	1-5(2)	
Ed-18	Rated transmission range	0-19999	
Ed-19	Power on reset operation	0-111	
Ed-20	Working mode	1-9	invisible
Ed-21	Acquisition speed	0-1	
Ed-24	Transmitting zero	0-4095	
Ed-25	Transmitting full scale	1-4095	
Ed-26	Transmitting negative bias	-9999-30000	
Ed-27	Communication mode	0=invalid, 1=Modbus RTU,2- active upload	
Ed-28	Communication machine code	1-128	
Ed-29	Communication speed	1-4.8k, 2-9.6k, 3-19.2k, 4-39.4k	
Ed-33	Input zero	-1000-10000	
Ed-34	Current zero	-9999-20000	
Ed-35	Input full scale	10000-32000	
Ed-36	Current coefficient	100-32700	
Ed-37	Gravity and speed	9.800	
Ed-41	Password	0-9999	
Ed-42	Multi-function code	10-19 Restore factory 20 parameter backup 30 recovery backup 40 Digital calibration	

Transmitting output example

The controller with a range of 1000kg can deliver output of 10V or 20mA at a full load.

1. Enter Ed-18 parameter, set the range of the controller is 1000.
2. Change the Ed-23 parameter to 1 and turn on transmitting output.
3. Connect a multimeter to terminal 1 and terminal 2.
4. Modify the Ed-24 parameter to make the multimeter measure to 0V or 4mA.
5. Modify the Ed-25 parameter to make the multimeter measure to 1V or 20mA.
6. When the sensor weighs 500kg, the terminal 1 and terminal 2 of the transmitting output can measure 5V or 12mA.

Display information

Upper display real-time value on the instrument, the lower the displayed information, see the following table:

Display symbols	The way	Remark
A	Output 1 alarm value	Peak value
b	Output 2 alarm value	Trigger threshold
c	Output 3 alarm value	Alarm upper limit
d	Alarm hysteresis	Alarm lower limit
AL	Alarm status	
st	Operating status	
E	A / D code value	
dA	Transmission output code	
U	Software version	

Calibration method

Weight calibration

The object can be calibrated of which weight should be more than 10% of the controller range and no more than 30000.

Step 1: Long press [k2] + to enter the password 200, F0xxxx showed up.

Step 2: When the controller is not weighed, press [k4] cleared to zero, show up F00000 zero to complete calibration.

Step 3: Press [k2], show up G00000, plus weights or known standard heavy objects.

Step 4: Press [k4] to enter the parameter modification interface. Press [k3] to increased value + [k2] to move the blinking bit and modify weight by weights.

Step 5: When stable, press [k2] to confirm, and the calibration is completed.

Step 6: The display value and input value is consistent. If it is not accurate, try the same process to calibrate it again. After calibrating it correctly, press [k1] returning force measurements interface.

Hardware calibration

Use known weight to calibrate with range coefficient, and the range coefficient value cannot exceed 32700.

Step 1: known weight (set as X).

Step 2: To weigh the object of known weight, after stable, check the value displayed on the controller (set as Y).

Step 3: Check the value of the coefficient in the Ed-36 parameter (set as Z).

Step 4: Calculate new coefficient i, $i=X/Y*Z$ (i=Standard weight/ display weight * Ed-36 value).

Step 5: Press [k4] and [k3] + to enter the value of new coefficient i into Ed-36.

Step 6: After modification, press [k1] to confirm. If it is not accurate, try the same process to calibrate it again.

Communication protocol

ATO-DPM-DY220 meter comes with a 485 communication interface, which can be used in either ModbusRTU or active transmission mode. ModbusRTU mode can read the current measured value and parameter value, modify parameter value and implement zero clearing function. In active transmission mode, this meter continuously sends packets of ASC11 code fixed with seven nodes.

Wiring diagram

