

PAPERLESS RECORDER

USER MANUAL



SKU: sisco-PLR-CH18

Preface

Thank you for purchasing our products!

This manual is about meter functions, settings, connection methods, operation flow, and methods to identify the faults.

Please read this manual carefully before operating and using it correctly to avoid unnecessary losses caused by false operation.

After reading it, please keep it properly in the place where you may read it any time for your reference.

Note

Modification of this manual's contents will not be notified as a result of some factors, such as function upgrading.

We try our best to guarantee that the manual content is accurate, if you find something wrong or incorrect, please contact us.

Any reprint and copy of the manual content is strictly prohibited either in whole or in part.

Contents

Chapter 1 Performance Index.....	1
1.1. Main parameters.....	2
1.2. Input signal.....	3
1.3. Output signal.....	4
1.4. Other parameters.....	4
Chapter2 Installation and Wiring.....	4
2.1. Unpacking.....	5
2.2. Installation.....	5
2.3. Wiring.....	7
2.3.1 The name and location of the terminal.....	7
2.3.2 Wiring signal lines.....	11
Chapter 3 Basic Operation Methods.....	12
3.1. Panel component.....	12
3.2. Button Operation.....	12
3.2.1. Screen Operation.....	12
3.2.2. Configuration login.....	22
3.2.3. Enable configuration.....	22
3.2.4. Parameters and setting.....	23
Chapter 4 Configuration instructions.....	28
4.1. Input Settings.....	28
4.1.1 Configuration Item Description.....	28
4.1.2 Alarm setting screen.....	29
4.2. AO output.....	30
4.3. Flow setting.....	31
4.4. Accumulation setting.....	33
4.5. Control setting.....	34
4.6. Function setting.....	35
4.6.1. Zero clearing.....	35
4.6.2. U disk operation.....	35
4.6.3. Communication setting.....	35
4.6.4. Remote setting.....	36
4.6.5. User-defined screen.....	38
4.7. System Settings.....	38
Appendix 1: Address and Examples of Modbus.....	40
Appendix 2: Calculation of flow coefficient K.....	42

Chapter 1 Performance Index



Overview

The paperless recorder set various industrial, measurement data in civil applications, display, processing, computing, alarming, and recording a variety of reports and other functions in it. It has a 18-channel analog signal input channel, 4-channel relay alarm output channel, 150mA distribution output channel (which can be accessed 6-way two-wire transmitter, or 2-way four-wire transmitter), an RS-485 communication interface it has a USB data dump interface.

In hardware, the enhanced SUP-R9600 Paperless Recorder replaces the 6-channel analog quantity input function with 4-channel analog quantity output and one RS-485 input function. In software, it adds 4-channel flow, 4-channel accumulation and 4-channel PID calculation function. Also, it includes a user-defined interface, which allows the user to arrange the channels in the interface at will.

Comparison of function between enhanced recorder and basic recorder:

Table1-1

Function	Basic type	Enhanced type
Analog quantity input	18 channels	1—12 channels
Analog quantity output	N/A	4 channels
Relay output	4 channels	4 channels
RS-485 output	Yes	Yes
RS-485 input	N/A	Yes
Power distribution	Yes	Yes
Flow (temperature and pressure compensation)	N/A	Yes
Accumulation	N/A	Yes
PID calculation	N/A	Yes
User-defined interface	N/A	Yes

The paperless recorder uses high-speed, high-performance 32-bit cortex-M4 microprocessor in its internal. Circuit board is handled through three anti-coating processes-----"anti-corrosion, anti-moisture, anti-dust". High-performance power meter has a strong anti-jamming capability and can effectively suppress external harmonic interference to improve the overall stability greatly.

The paperless recorder can be used in metallurgy, petroleum, chemicals, building materials, paper, electricity, food, pharmaceutical, industrial water treatment and other industries.

1.1.Main parameters

Table1-2 The main parameters

Display	3.5-inch TFT true color LCD screen. resolution is 320 * 240
Dimension	Dimension: 96mm×96mm×100mm Mounting : 92mm×92mm
Thickness of mounted panel	1.5mm~6.0mm
Weight	0.37kg
Power supply	(176~264)VAC, 47~63Hz (24VDC can be customized)
Internal storage	48Mbytes Flash
External storage	U disk support (standard USB2.0 communication interface)
The maximum power consumption	20VA

Relative humidity	(10~85)%RH (No condensation)
Operating temperature	(0~50)°C
Transport and storage conditions	temperature (-20~60)°C, Relative humidity (5~95)%RH (No condensation)

1.2.Input signal

Table1-3 DC voltage / current input

Type	The maximum permissible error (%FS)
(1~5) V	±0.1
(0~10) V	
(0~5) V	
(0~100) mV	
(4~20) mA	±0.2
(0~20) mA	
(0~10) mA	
(-20~20) mV	±0.25
(0~20) mV	

Table1-4 thermocouple input (not include cold junction error)

Type	Measure range (°C)	The maximum permissible error (°C)
B	600 ~ 1800	±2.4
E	-200 ~ 1000	±2.4
J	-200 ~ 1200	±2.4
K	-200 ~ -100	±3.3
	-100 ~ 1300	±2.0
S	-50 ~ 100	±3.7
	100 ~ 300	±2.0
	300 ~ 1600	±1.5
T	-200 ~ -100	±1.9
	-100 ~ 380	±1.6
R	-50 ~ 100	±3.7
	100 ~ 300	±2.0
	300 ~ 1600	±1.5
N	-200 ~ 1300	±3.0

Table1-5 RTD input

Type	Measure range (°C)	The maximum permissible error (°C)
Cu50	-50 ~ 140	±1.0
Pt100	-200 ~ 800	±1.0

NOTE: special RTD can be customized, like Pt1000 etc

1.3. Output signal

Table 1-6 The alarm output

Type	Scalerange	Contact types	Contact capacity	Response cycle
The alarm	0/1	Normally opencontacts	2A/250VAC	1 second

Table 1-7 Current output

Type	Range (mA)	Maximum permissible error
Current output	4 ~ 20	±0.2

1.4. Other parameters

Table 1-8 Other parameters

Fuse Specifications	3.15A/250VAC, Hard-fusing type
power distribution specifications	150mA, 24 VDC.
Power failureprotection	All data is stored in Flash storage to make sure that all historical data and configuration parameters are not lost due to power failure. The real-time clock powered by a lithium battery after power failure.
Alarm output	It has up to 4 channels. Relays are normally open contacts and the contact capacity is 2A / 250VAC (resistiveload).
Communication Interface	1channel RS485 communication interface.one RS-485 input (optional)
Communication protocol	Using Modbus communication protocol
Sampling period	1s

Chapter2 Installation and Wiring

This chapter describes the installation and wiring methods of this instrument. It is necessary for technicians to learn when they use the instrument for the first time.

This is a procedure which enables the instrument to normal operation, as the table2-1

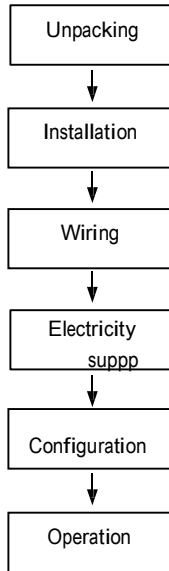

Figure 2-1 Flow diagram from unpacking to operation

2. 1. Unpacking

Upon receipt of the instrument, Please check the packaging whether intact or not. Do not put excessive force to the box when unpacking the box. The box should be facing up opened from the seal. Remove the instrument from the box carefully to make sure the housing is not deformed, broken or cracked. You can check the packing list of the machine equipment and other items.

2. 2. Installation

Instrument operating environment will not only affect the normal use of the instrument, but also affect the maintenance and calibration work. Instrumentation environment should meet the following requirements:

Indoor installation

Operating temperature: (0~50)°C

Relative humidity: (10~85)%RH (No condensation)

Ventilation requirements: ventilated to prevent the internal meter temperature is too high

Vibration disturbance: Less mechanical vibration

Air ingredients: NOT easy to produce condensate, non-corrosive gas or flammable gas

Inductive interference: no strong inductive interference, not easy to produce static electricity, magnetic fields or noise

Meter position: When installing the instrument, try to maintain the level and do not tilt left and right

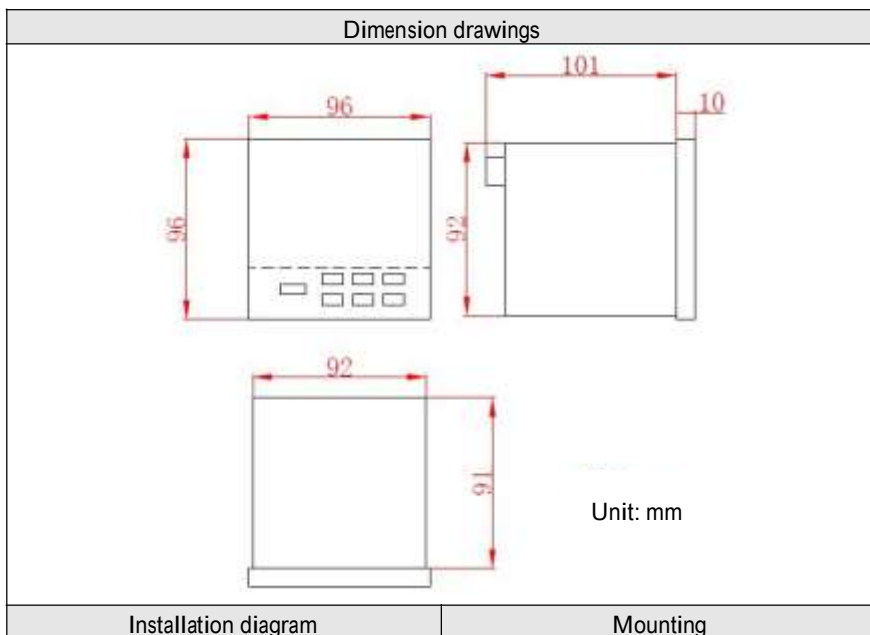

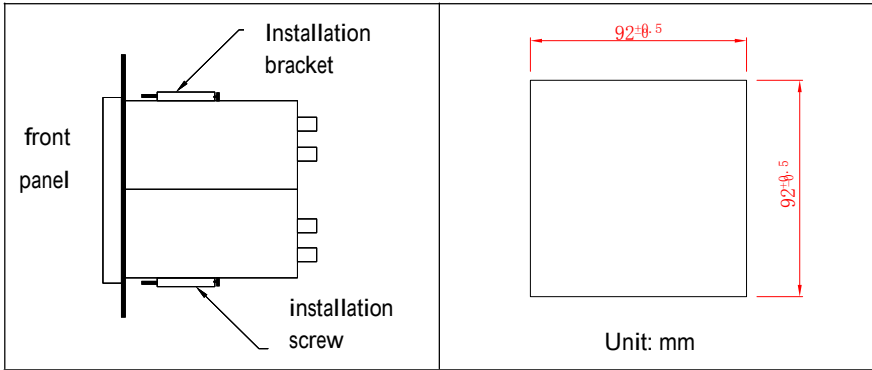

Figure 2-2 Product dimension and installation drawing

2.3. Wiring

In order to improve the stability and accuracy of the signals, it is recommended that you use the cold terminal signal cable to wire.

2.3.1 The name and location of the terminal

Terminal arrangement is shown in figure 2-3 、 figure 2-4. Specific definition of terminal symbols and Explanation are described in figure 2-1.

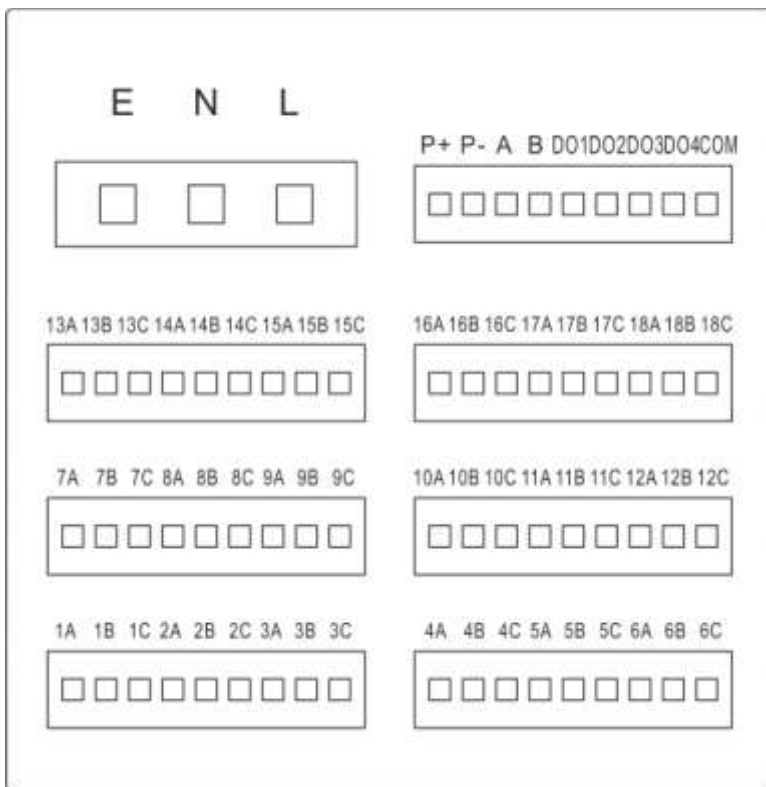

Figure 2-3 Terminal view of basic type

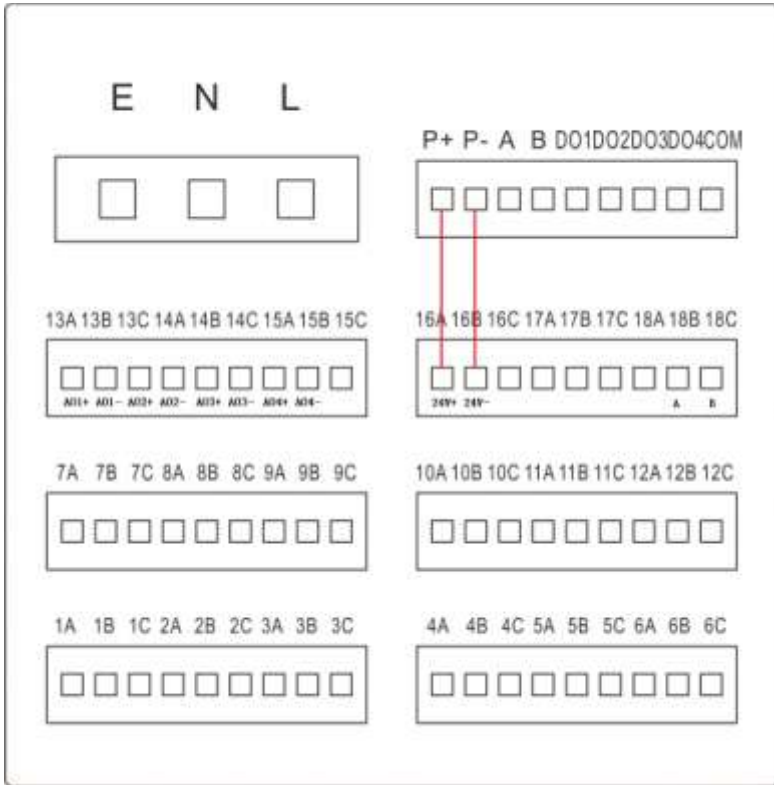

Figure 2-4 Terminal view of enhanced type

NOTE:

The analog quantity output board needs an external 24V power supply, which can be provided by the power adapter accompanied with the product. As the power is large, please do not power any other transmitter at this time.

Table2-1 Specific instructions of each terminal

Terminal No.	Signal type	Description
E、N、L	E、N、L	24VDC power supply: L is 24V+; N is 24V-; E is undefined. AC Power (single-phase three wire system) terminal block: L is Phase line terminals, N is Zero line terminals, E is Ground terminal.
Signal input Terminal Description		
1A, 1B, 1C	universal input	analog input channel 1
2A, 2B, 2C	universal input	analog input channel 2
3A, 3B, 3C	universal input	analog input channel 3
4A, 4B, 4C	universal input	analog input channel 4
5A, 5B, 5C	universal input	analog input channel 5
6A, 6B, 6C	universal input	analog input channel 6
7A, 7B, 7C	universal input	analog input channel 7
8A, 8B, 8C	universal input	analog input channel 8
9A, 9B, 9C	universal input	analog input channel 9
10A, 10B, 10C	universal input	analog input channel 10
11A, 11B, 11C	universal input	analog input channel 11
12A, 12B, 12C	universal input	analog input channel 12
13A, 13B, 13C	universal input	analog input channel 13
14A, 14B, 14C	universal input	analog input channel 14
15A, 15B, 15C	universal input	analog input channel 15
16A, 16B, 16C	universal input	analog input channel 16
17A, 17B, 17C	universal input	analog input channel 17
18A, 18B, 18C	universal input	analog input channel 18
Signal output Terminal Description		
A	485+	communication port RS-485
B	485-	communication port RS-485
Distribution output Terminal Description		

Table2-2 Specific instructions of each terminal

Terminal No.	Signal type	Description
P+	/	24V+
P-	/	24V-
Alarm output Terminal Description		
DO1	Relays	Alarm output Channel 1
DO2	Relays	Alarm output Channel 2
DO3	Relays	Alarm output Channel 3

DO4	Relays	Alarm output Channel 4
COM		Alarm Commons

Instructions for enhanced type terminal:

Terminal No.	Signal type	Description
13A, 13B	Current output	Analog quantity output of the first channel
13C, 14A	Current output	Analog quantity output of the second channel
14B, 14C	Current output	Analog quantity output of the third channel
15A, 15B	Current output	Analog quantity output of the fourth channel
16A, 16B	Power distribution input of the board	16A: 24V+, 16B: 24V-
18B, 18C	RS-485 input	18B: A, 18C: B

2.3.2 Wiring signal lines

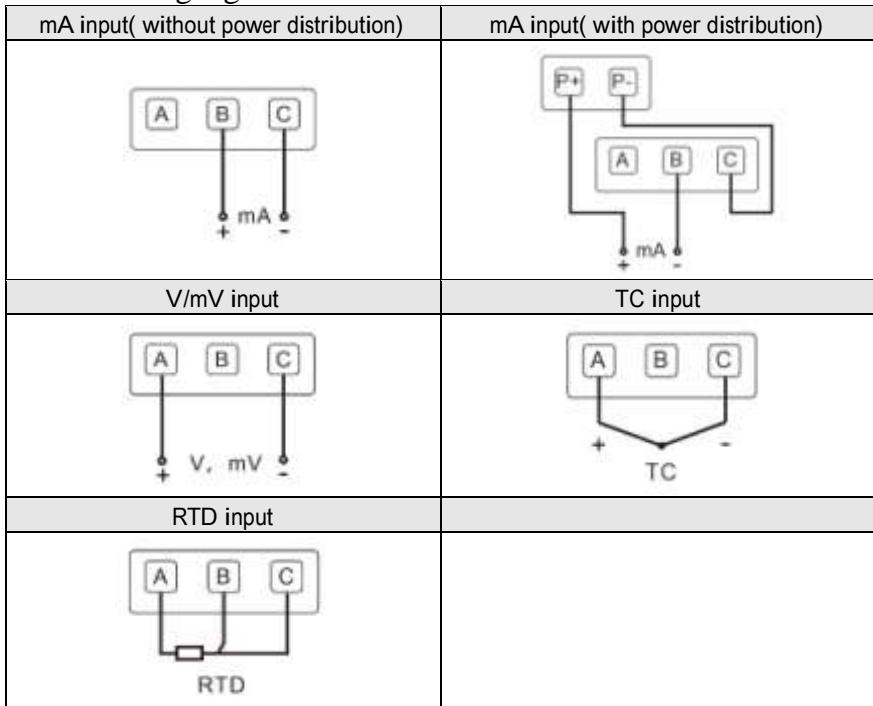

Figure 2-5 Schematic diagram of signal cables

Chapter 3 Basic Operation Methods



Figure 3-1 Panel component distribution

Panel component distribution of paperless recorder is shown in figure3-1.

3. 1. Panel component

LCD Screen: Display monitor and configuration.

Button:

Button	Name of button	Button	Name of button
	Up key		Right key
	Down key		Enterkey
	Leftkey		Cancel key

3. 2. Button Operation

3. 2. 1. Screen Operation

Information bar	Screen Description
<p>Indicating U disk</p> <p>16-03-07 16:00:37</p> <p>Indicating alarm System time</p> <p>Indicating low battery</p>	<ul style="list-style-type: none"> <input type="checkbox"/> Battery Capacity: Replace the batteries when there is such a sign, Pay attention to backup data before replacement <input type="checkbox"/> Alarm: When there is an alarm message appears, please enter the alarm screen to check it and then it will disappear. <input type="checkbox"/> U disk Tip: When insert U disk ,this sign

	<p>will appear.</p> <ul style="list-style-type: none"> <input type="checkbox"/> System time: Time of present system
Front Panel	Screen Description
	<ul style="list-style-type: none"> <input type="checkbox"/> Show all bit of analog input resolution, instantaneous value, units and alarm status <input type="checkbox"/> “ XXXXX ” represents the channel disconnection <input type="checkbox"/> You can switch the former and later picture through left key and right key.
Digital display screen	Screen Description
	<ul style="list-style-type: none"> <input type="checkbox"/> Display channel bit number, the instantaneous value, units and alarm status. <input type="checkbox"/> Pressing up-key can switch channel. <input type="checkbox"/> You can switch the former and later picture through left key and right key.
Digital display screen (original signal)	Screen Description
	<ul style="list-style-type: none"> <input type="checkbox"/> Display channel bit number, the instantaneous value of the original signal and the signal type. <input type="checkbox"/> Pressing up-key can switch channel. <input type="checkbox"/> You can switch the former and later picture through left key and right key.
Bar graph screen (vertical)	Screen Description
	<ul style="list-style-type: none"> <input type="checkbox"/> Display channel bit number, the instantaneous value, units and alarm status. <input type="checkbox"/> Pressing up-key can switch channel. <input type="checkbox"/> You can switch the former and later picture through left key and right key.
Bar graph screen (horizontal)	Screen Description

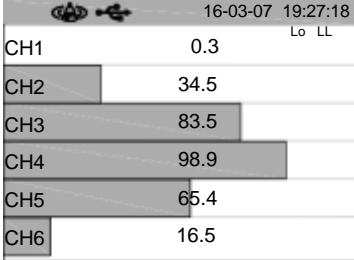
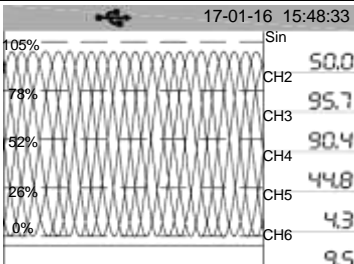
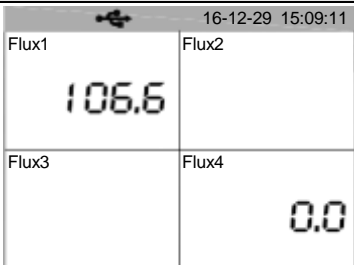
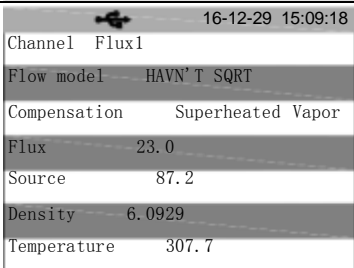

 <table border="1"> <thead> <tr> <th>Channel</th> <th>Value</th> </tr> </thead> <tbody> <tr> <td>CH1</td> <td>0.3</td> </tr> <tr> <td>CH2</td> <td>34.5</td> </tr> <tr> <td>CH3</td> <td>83.5</td> </tr> <tr> <td>CH4</td> <td>98.9</td> </tr> <tr> <td>CH5</td> <td>65.4</td> </tr> <tr> <td>CH6</td> <td>16.5</td> </tr> </tbody> </table>	Channel	Value	CH1	0.3	CH2	34.5	CH3	83.5	CH4	98.9	CH5	65.4	CH6	16.5	<ul style="list-style-type: none"> <input type="checkbox"/> Display channel bit number, the instantaneous value, units and alarm status. <input type="checkbox"/> Pressing up-key can switch channel. <input type="checkbox"/> You can switch the former and later picture through left key and right key.
Channel	Value														
CH1	0.3														
CH2	34.5														
CH3	83.5														
CH4	98.9														
CH5	65.4														
CH6	16.5														
Real-time curve interface	Screen Description														
 <p>17-01-16 15:48:33</p> <p>105% Sin</p> <p>78% CH2 50.0</p> <p>52% CH3 95.7</p> <p>26% CH4 90.4</p> <p>0% CH5 44.8</p> <p>CH6 4.3</p> <p>9.5</p>	<ul style="list-style-type: none"> <input type="checkbox"/> Real-time curve display: Channel number, instantaneous value <input type="checkbox"/> Press Addition key can switch channels. <input type="checkbox"/> Press Left/Right key can switch the previous and the current interfaces. 														
Flow interface	Screen Description														
 <p>16-12-29 15:09:11</p> <p>Flux1 106.6</p> <p>Flux2</p> <p>Flux3</p> <p>Flux4 0.0</p>	<ul style="list-style-type: none"> <input type="checkbox"/> Display items of flow channel: channel number, instantaneous value, unit and alarm state. <input type="checkbox"/> Press Left/Right key can switch the previous and the current interfaces. 														
 <p>16-12-29 15:09:18</p> <p>Channel Flux1</p> <p>Flow model HAVN' T SQRT</p> <p>Compensation Superheated Vapor</p> <p>Flux 23.0</p> <p>Source 87.2</p> <p>Density 6.0929</p> <p>Temperature 307.7</p>	<ul style="list-style-type: none"> <input type="checkbox"/> Press Addition key can switch and check detailed information of the channel. <input type="checkbox"/> Allow check of more parameters: temperature, pressure and density ,etc. <input type="checkbox"/> Continue to press Addition key to return to the initial state. 														

<p>Accumulation interface</p>	<p>Screen Description</p>
	<ul style="list-style-type: none"> <input type="checkbox"/> Display instantaneous value and total accumulation value at the same time. <input type="checkbox"/> Press Left/Right key can switch the previous and the current interfaces.
<p>Log screen</p>	<p>Screen Description</p>
	<ul style="list-style-type: none"> <input type="checkbox"/> Display the log information. <input type="checkbox"/> Pressing up-key can switch channel. <input type="checkbox"/> You can switch the former and later picture through left key and right key.

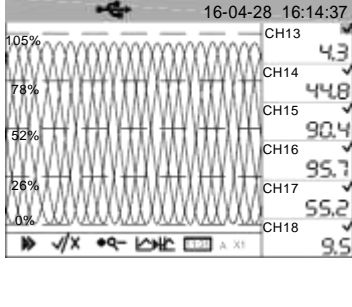
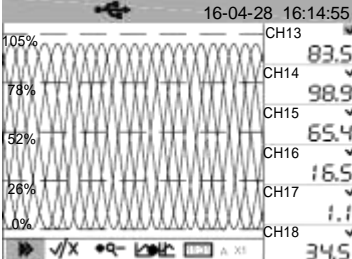
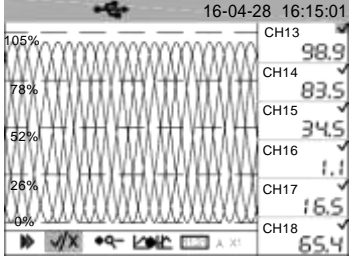
Power off safeguard screen	Screen Description																				
<p>16-12-29 15:09:57</p> <p>NO PowerOff Time PowerOn time</p> <table border="1"> <tr> <td>0013</td> <td>16-12-29 14:59:53</td> <td>16-12-29 15:00:04</td> <td>000h00m11s</td> </tr> <tr> <td>0012</td> <td>16-12-29 14:42:29</td> <td>16-12-29 14:42:50</td> <td>000h00m11s</td> </tr> <tr> <td>0011</td> <td>16-12-29 14:16:47</td> <td>16-12-29 15:19:58</td> <td>000h00m11s</td> </tr> <tr> <td>0010</td> <td>16-12-29 14:17:25</td> <td>16-12-29 14:17:53</td> <td>000h00m02s</td> </tr> <tr> <td>0009</td> <td>16-12-29 14:11:55</td> <td>16-12-29 14:12:04</td> <td>000h00m09s</td> </tr> </table> <p>00016h11m44s</p>	0013	16-12-29 14:59:53	16-12-29 15:00:04	000h00m11s	0012	16-12-29 14:42:29	16-12-29 14:42:50	000h00m11s	0011	16-12-29 14:16:47	16-12-29 15:19:58	000h00m11s	0010	16-12-29 14:17:25	16-12-29 14:17:53	000h00m02s	0009	16-12-29 14:11:55	16-12-29 14:12:04	000h00m09s	<ul style="list-style-type: none"> <input type="checkbox"/> Display power off time and power on time and cumulative time of power off. <input type="checkbox"/> Pressing up-key can switch channel. <input type="checkbox"/> You can switch the former and later picture through left key and right key.
0013	16-12-29 14:59:53	16-12-29 15:00:04	000h00m11s																		
0012	16-12-29 14:42:29	16-12-29 14:42:50	000h00m11s																		
0011	16-12-29 14:16:47	16-12-29 15:19:58	000h00m11s																		
0010	16-12-29 14:17:25	16-12-29 14:17:53	000h00m02s																		
0009	16-12-29 14:11:55	16-12-29 14:12:04	000h00m09s																		
Report interface	Screen Description																				
<p>17-01-16 15:58:12</p> <p>ACC1 Hour Report 0001/0001</p> <p>NO Time</p> <table border="1"> <tr> <td>0001</td> <td>17-01-16</td> <td>14:00-15:00</td> <td>44.5</td> </tr> </table> <p>17-01-16 15:58:22</p> <p>ACC2 Hour Report</p> <p>NO Time</p> <p>17-01-16 15:58:31</p> <p>ACC2 Hour Report 0001/0001</p> <p>NO Time</p> <table border="1"> <tr> <td>0001</td> <td>17-01-16</td> <td>14:00-15:00</td> <td>44.3</td> </tr> </table>	0001	17-01-16	14:00-15:00	44.5	0001	17-01-16	14:00-15:00	44.3	<ul style="list-style-type: none"> <input type="checkbox"/> Display accumulation time report. <input type="checkbox"/> Press Addition key can switch the location of blue cursor. <input type="checkbox"/> Allow switch of previous and the current interface and channel. 												
0001	17-01-16	14:00-15:00	44.5																		
0001	17-01-16	14:00-15:00	44.3																		

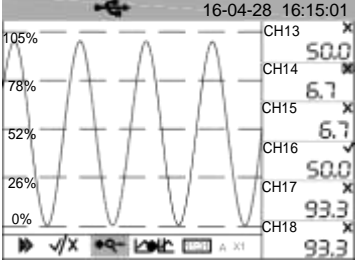
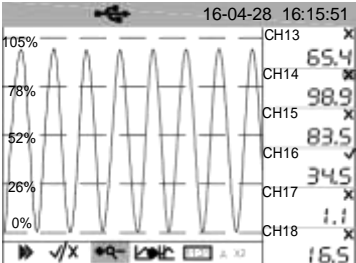
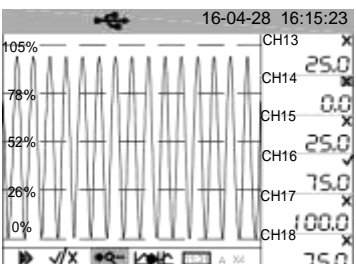
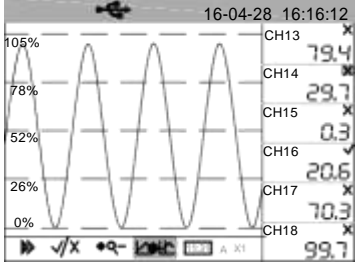
Alarm screen	Screen Description
	<ul style="list-style-type: none"> <input type="checkbox"/> Display alarm channel, type, beginning and ending time of alarm. <input type="checkbox"/> Pressing up-key can switch channel. <input type="checkbox"/> You can switch the former and later picture through left key and right key.
History screen	Screen Description
	<ul style="list-style-type: none"> <input type="checkbox"/> The historic interface includes two modes: real-time mode and historic mode. <input type="checkbox"/> Under real-time mode, the data will be refreshed according to record intervals. Historic mode is a query mode under which relevant historic data will be displayed according to the input time. <input type="checkbox"/> Press Addition key can switch of status. <input type="checkbox"/> You can switch the former and later picture through left key and right key.
History screen-1	Screen Description
	<ul style="list-style-type: none"> <input type="checkbox"/> Pressing Addition key reaches channel switch status first. <input type="checkbox"/> Press Left/Right key can switch channels, continue to press Addition key to switch to the next state.
History screen-2	Screen Description
	<ul style="list-style-type: none"> <input type="checkbox"/> Press Addition key again to switch to blanking state. <input type="checkbox"/> At this time, press Left/Right key to select channels to be blanked. <input type="checkbox"/> Press Confirmation key to blank or display the selected curve.

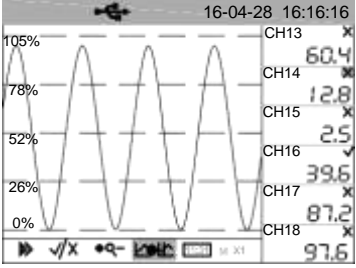
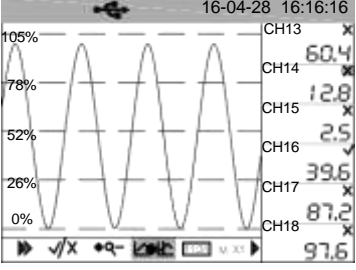
History screen-3	Screen Description
 <p>16-04-28 16:15:01</p> <p>105% 78% 52% 26% 0%</p> <p>CH13 50.0 CH14 6.7 CH15 6.7 CH16 50.0 CH17 93.3 CH18 93.3</p> <p>One time</p>  <p>16-04-28 16:15:51</p> <p>105% 78% 52% 26% 0%</p> <p>CH13 65.4 CH14 98.9 CH15 83.5 CH16 34.5 CH17 1.1 CH18 16.5</p> <p>Two times</p>  <p>16-04-28 16:15:23</p> <p>105% 78% 52% 26% 0%</p> <p>CH13 25.0 CH14 0.0 CH15 25.0 CH16 75.0 CH17 100.0 CH18 75.0</p> <p>Four times</p>	<ul style="list-style-type: none"> <input type="checkbox"/> Press Addition key again to switch to the zoom state. <input type="checkbox"/> Press Left/Right key can change the displayed times. There are three choices of 1,2,4 times. Continue to press Addition key to switch to the next state.
History screen-4	Screen Description
 <p>16-04-28 16:16:12</p> <p>105% 78% 52% 26% 0%</p> <p>CH13 79.4 CH14 29.7 CH15 0.3 CH16 20.6 CH17 70.3 CH18 99.7</p> <p>Auto mode state: A</p>	<ul style="list-style-type: none"> <input type="checkbox"/> Press Addition key again to switch to real-time/historic mode switch state. <input type="checkbox"/> At this time, Left/Right key can change the real-time mode and historic mode state, Continue to press Addition key to switch to the next state.

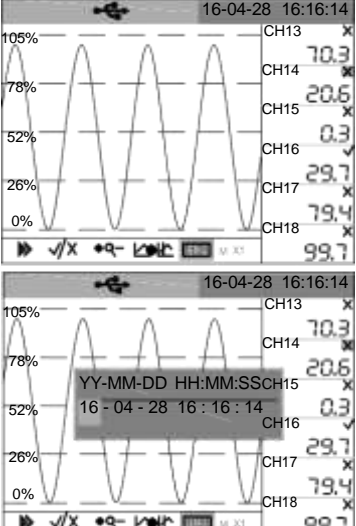
 <p>Historic mode state: M</p>	
<p>History screen-5</p>	<p>Screen Description</p>
	<ul style="list-style-type: none"> <input type="checkbox"/> Under historic mode, press Addition key to switch to manual query mode (An arrow  occurs). <input type="checkbox"/> At this time, Left/Right key enable check of previous and current historic data value. Press and hold this key can move quickly. <input type="checkbox"/> Continue to press Addition key to switch to the next state.
<p>History screen-6</p>	<p>Screen Description</p>
	<ul style="list-style-type: none"> <input type="checkbox"/> Press Addition key again to switch to query mode of fixed point. <input type="checkbox"/> At this time, if pressing Confirmation key, time setting will pop up. <input type="checkbox"/> Set the time and press Confirmation key, then you can perform query. <input type="checkbox"/> Press Addition key again to exit operation state in historic state.

Data save interface	Screen Description
	<ul style="list-style-type: none"> <input type="checkbox"/> Can save historic data. With HDA and CSV format available (You can check it at a host computer). Records pertaining to alarms, power loss, logs, can be saved in CSV format. (NOTE 1) <input type="checkbox"/> The saved data is displayed on the lower right part for ease of check.
Data save interface-1	Screen Description
	<ul style="list-style-type: none"> <input type="checkbox"/> Setting start time and end time can save part of historic data in HDA format.
user-defined interface	Screen Description
	<ul style="list-style-type: none"> <input type="checkbox"/> Channel of user-defined interface is customized. If not, then it's unavailable. <input type="checkbox"/> You can switch the former and later picture through left key and right key.
PID overview	Screen Description
	<ul style="list-style-type: none"> <input type="checkbox"/> The bar graph displays 4-channel PID measurement value, setting value, output value and manual/auto state.

PID debugging	Screen Description
	<ul style="list-style-type: none"> <input type="checkbox"/> Show PID loop information in detail, including PID parameters to facilitate debugging.
	<ul style="list-style-type: none"> <input type="checkbox"/> Press Addition key can switch the location of gray cursor, Left/Right key modifies the channel, manual/auto state, setting value/output value and given internal and external state. PID parameter cannot be modified.

【Note 1】 : File saving path

Files of this recorder are all saved in relevant folders corresponding to the root directory (recorder name). The recorder name can be modified in “system setting” configuration.

File name:

Document	Subdirectory	File name
Historic record	/History	H160109A.csv/ H160109A.hda
Accumulation record	/Info	A160109A.csv
Alarm information	/Info	B160109A.csv
Power off record	/Info	P160109A.csv
Logrecord	/Info	L160109A.csv

Where:

The initial letter H、A、B、P、L denotes file type. The six numbers that follow represent the saved date. The last letter can be A~Z, indicating that a type can be saved for 26 times a day. If it's full, then the no files can be saved.

Tips:

After inserting a U disk, it the system identifies such disk, it will automatically transfer and save the data into the U disk at exactly 2 o'clock every day.

3. 2. 2. Configuration login

Step	Interface	Operation
1		<ul style="list-style-type: none"> Under the left interface, press and hold and key to enter login interface.
2		<ul style="list-style-type: none"> Press Left/Right key to switch the location of the cursor, and press Confirmation key to enter configuration or input password. When entering the password, pressing Addition/deletion key to modify the password. Left/Right key can modify the location of numbers. Pressure Conformation key for confirmation of the input.
3		<ul style="list-style-type: none"> Confirm the correct password, select enter configuration and press Confirmation key to login.

3. 2. 3. Enable configuration

Step	Interface	Operation
1		<ul style="list-style-type: none"> After completing modification, press Cancel key until the configuration interface appears.
2		<ul style="list-style-type: none"> Press Cancel key again. If the configuration is modified, a confirmation dialog box will appear. If not, enter the monitoring interface directly.

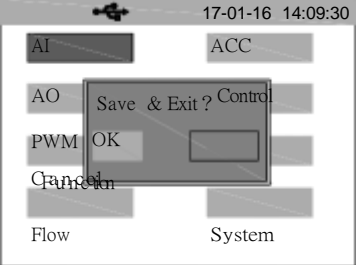
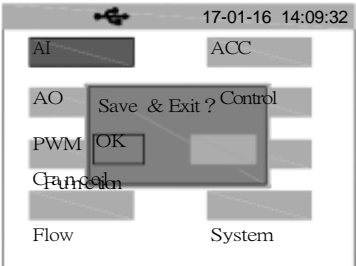
Step	Interface	Operation
		
3		<ul style="list-style-type: none"> <input type="checkbox"/> Select "OK" and press Confirmation key. NOTE: The cursor selects "Cancel" by default.

3. 2. 4. Parameters and setting

Digital input

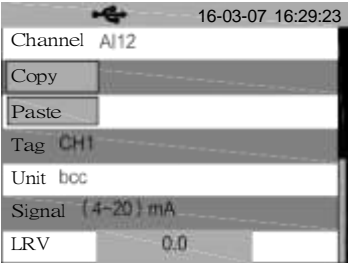
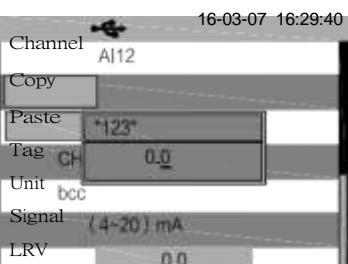
Step	Interface	Operation
1		<ul style="list-style-type: none"> <input type="checkbox"/> Select the parameter to be modified, and press Confirmation key.
2		<ul style="list-style-type: none"> <input type="checkbox"/> Left/Right key can select the parameter location to be modified.
3		<ul style="list-style-type: none"> <input type="checkbox"/> Addition/Deletion key can modify

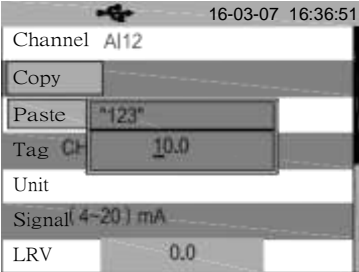
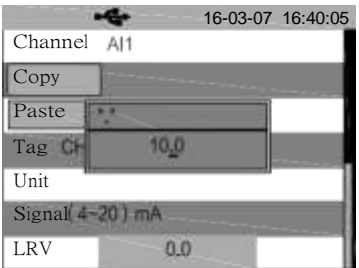
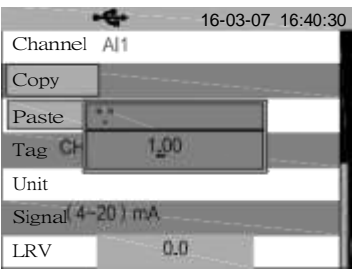
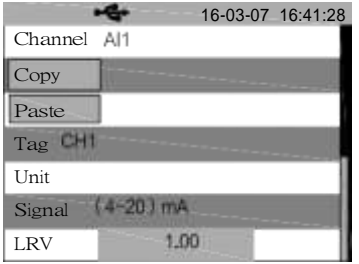
Step	Interface	Operation
		<p>the numbers at the selected location.</p>
4		<ul style="list-style-type: none"> <input type="checkbox"/> After entering, press Confirmation key to adjust the decimal point.
5		<ul style="list-style-type: none"> <input type="checkbox"/> Left/Right key can modify the location of decimal point.
6		<ul style="list-style-type: none"> <input type="checkbox"/> Press Confirmation key again to complete numerical entering. <input type="checkbox"/> Press Cancel key to cancel the modification.

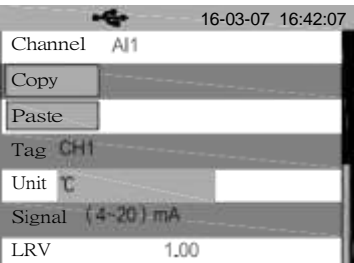
Step	Interface	Operation
		

Input of bit channel No. and unit

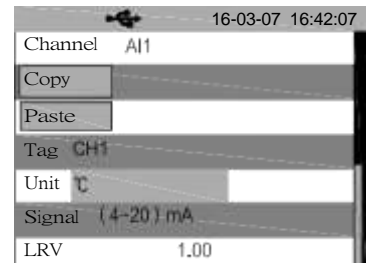
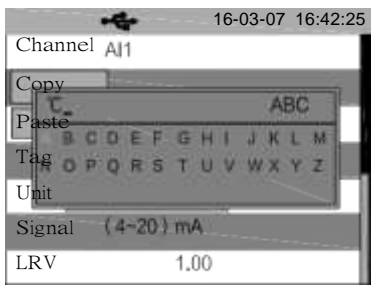
Step	Interface	Operation
1		<p><input type="checkbox"/> Select the parameter to be modified, and press Confirmation key.</p>
2		<p><input type="checkbox"/> Press Addition key can switch the type of input character.</p>

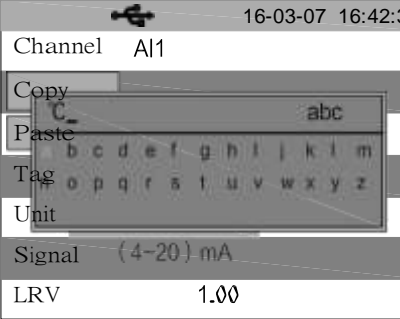
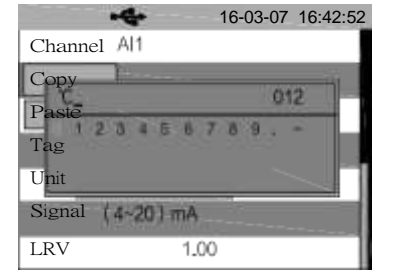
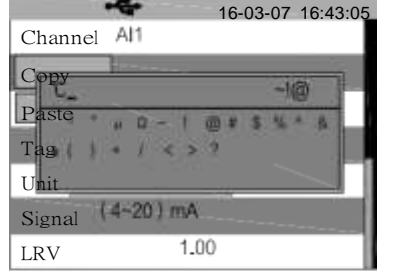
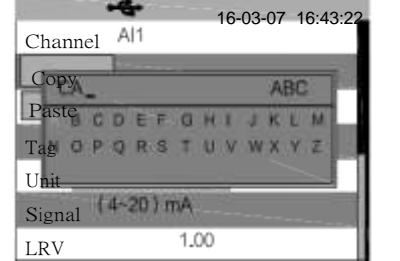
Step	Interface	Operation
	  	
3		<ul style="list-style-type: none"> <input type="checkbox"/> Press Left/Right key can select the input character. <input type="checkbox"/> Press Confirmation key for confirmation. <input type="checkbox"/> Press Deletion key to delete input. <input type="checkbox"/> Press Cancel key to exit.

Choice box

Step	Interface	Operation
1		<ul style="list-style-type: none"> <input type="checkbox"/> Select the parameter to be modified, and press Confirmation key.
2		<ul style="list-style-type: none"> <input type="checkbox"/> Left/Right key can select items. <input type="checkbox"/> Confirmation key saves the items and exits. <input type="checkbox"/> Cancel key cancels and exits.

System time

Step	Interface	Operation
1		<ul style="list-style-type: none"> <input type="checkbox"/> Select the parameter to be modified, and press Confirmation key. <input type="checkbox"/> Left/Right key can select location. <input type="checkbox"/> Addition/Deletion key can modify numbers (letters). <input type="checkbox"/> Confirmation key saves the items and exits, Cancel key cancels and exits.

Recorder name

Step	Interface	Operation
1		<ul style="list-style-type: none"> <input type="checkbox"/> Select the parameter to be modified, and press Confirmation key. <input type="checkbox"/> Left/Right key can select location. <input type="checkbox"/> Addition/Deletion key can modify numbers (letters). <input type="checkbox"/> Confirmation key saves the items and exits, Cancel key cancels and exits.

Tips: Under Input setting mode, the channel can be switched by Addition/Deletion key

Chapter 4 Configuration instructions

This chapter introduces the individual configuration parameters of instrument.

4.1.Input Settings

4.1.1 Configuration Item Description:

configuration Item	Function Description	Parameter range
Channel	Select set analog channel	A11~A18(The real display shall prevail.)
Copy	Copy the configuration	
Paste	Paste the copied configuration information	
Bit	Set bit of the analog channel	Custom string's length is 8
Unit	Set the unit for analog channel	Custom string's length is 8
Signal	Setting Signal Types	(4~20) mA、(0~20) mA、(0~10) mA、PT100、Cu50、(1~5) V、(0~10) V、(0~5) V、B、E、J、K、S、T、R、N、(0~20) mV、(-20~20) mV、(0~100) mV
Lower Range limit	Set lower Range limit	-99999~99999
Upper Range limit	Set upper range limit	-99999~99999
Correction factor A	A in $Y=A*X+B$	-99999~99999
Correction factor B	B in $Y=A*X+B$	-99999~99999

First-order filter	First-order filter parameter	0s, 1s, 2s, 5s, 10s, 15s, 30s
Disconnection display	Displays the value of channel disconnection	-99999~99999
Alarm setting	Enter to alarm setting screen.	

4.1.2 Alarm setting screen

configuration Item	Function Description	Parameter range
Higher alarm HH	Higher alarm value	-99999~99999
Higher alarm output	Higher alarm output terminal	None, DO1, DO2, DO3, DO4 (The real display shall prevail.)
High alarm Hi	High alarm value	-99999~99999
High alarm output	High alarm output terminal	None, DO1, DO2, DO3, DO4 (The real display shall prevail.)
Low alarm Lo	Low alarm value	-99999~99999
Low alarm output	Low alarm output terminal	None, DO1, DO2, DO3, DO4 (The real display shall prevail.)
Lower alarm LL	Lower alarm value	-99999~99999
Lower alarm output	Lower alarm output terminal	None, DO1, DO2, DO3, DO4 (The real display shall prevail.)
Hysteresis	Alarm Hysteresis	-99999~99999

Note: Hysteresis prevents repeated alarm when the measures date fluctuates from the alarm point. The high or low level alarm and Hysteresis figure is showed in Figure 4-1 below. At high level alarm, when the actual engineering value is larger than or equal to the alarm value, the recorder enters into the alarm state. When the input is reduced, the actual engineering value is less than the alarm value, but the recorder will not exit the alarm state immediately. Until the actual engineering value is less than the alarm value and Hysteresis value, will the recorder exit the alarm state. The same is for low level alarm.

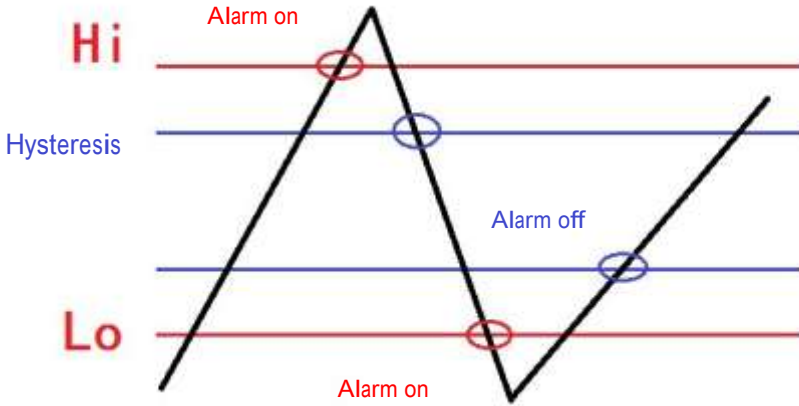

Figure 4-1: High or low level alarm and Hysteresis

4.2.AO output

The current output module provides 4 independent 4~20 mA current output. It can output measurement value, flow value and PID calculation value. It can also achieve transferring output and PID control function.

Configuration Item Description:

configuration Item	Function Description	Parameter range
Channel	Select AO channel	AO1~AO4
State	Enable/Disenable this channel	Enable/Disenable
Signal source	Channel to be output	AI1~AI12、FLOW1~FLOW4、PID1~PID4、VA1~VA4 【Note 1】
Signal type	Output analog quantity type	(4~20) mA 【Note 2】
Lower limit of range	Lower limit of channel	-99999~99999
Upper limit of range	Upper limit of channel	-99999~99999
Zero mark calibration mA	Can be slightly adjusted in mA.	-5mA~5mA

【Note 1】 :

VA is the special channel defined by the user. If you have not defined this channel, please ignore it.

【Note 2】 :

$$\text{Current output} = \frac{\text{Signal source} - \text{Lower limit of range}}{\text{Upper limit of range} - \text{Lower limit of range}} * 16\text{mA} + 4\text{mA} + \text{Zero mark calibration}$$

4.3.Flow setting

The flow function can be used to measure such medium as superheated steam, saturated steam, general gas, mixed gas, natural gas, coal gas, water, hot water, chemical liquid,etc. It's applicable to be used with the vortex flowmeter, turbine flowmeter, V-cone flowmeter, elbow flowmeter, electromagnetic flowmeter, mass flowmeter, orifice flowmeter, nozzle flowmeter, classic venturi and other flow products.

Configuration Item Description:

configuration Item	Function Description	Parameter range
Channel	Select flow channel	FLOW1~FLOW4
State	Enable/Disenable thi	Enable/Disenable
Unit	The display unit in flow interface	User-defined 8-bit character string
Signal source	Channel of flow signal	A11~A18 【Note1】
Lower limit of range	Lower limit of range after flow compensation	-99999~99999
Upperlimit of range	Upper limit of range after flow compensation	-99999~99999
Flow model	Select formula suitable for restrictionchoke	No extraction of a root 、 No extraction of a root for differential pressure 、 Extraction of a root for differential pressure 【Note 2】
Signal removal	Removal of small flow	-99999~99999
Flow coefficient	K in the formula 【Note 2】	-100000000~100000000
Compensation mode	Select algorithm of density compensation	Given density, superheated steam, saturated steam P, saturated steam T, general gas, without compensation, temperature linear compensation, pressure linear compensation 【Note 3】
Pressure signal	P in density compensation	None、 A11~A18 【Note 1】

	inMPa	
Emergency pressure	Emergency value in case of abnormal pressure	-100000000~100000000
Temperature signal	T in density compensation in °C	None、A11~A18 【Note 1】
Emergency temperatur	Emergency value in case of abnormal temperature	-100000000~100000000
Linear compensation A	Use in Note 3	-100000000~100000000
Linear compensation B	Use in Note 3	-100000000~100000000
Heat calculation	Select the model for heat calculation	Close, give enthalpy, auto calculation 【Note 4】
Given enthalpy	Used when selecting a given enthalpy	-100000000~100000000
Alarm setting	Enter alarm setting interface	

【Note 1】 :When mode A or remote Modbus input is selected, only A11~A12 is available.

【Note 2】 : Methods for calculating flow are various, such as throttling model, speed model, pulse frequency model, volumetric model, mass model, and so on.

In this recorder, three types of methods are concluded:

Flow model	Formula
No extraction of a root	$Q = K \cdot I_f^*$
No extraction of a root for differential pressure	$Q = K \cdot \sqrt{P^*}$
Extraction of a root for differential pressure	$Q = K \cdot P^* \sqrt{\quad}$

Where:

Q: Mass flow rate K:

Flow coefficient

ρ : Fluid density

P : Differential pressure signa

I_f : Flow value of restriction choke. It may be a current signal or a frequency signal.

【Note 3】 : It can be seen from the flow model that the calculation of mass flow is directly related with the fluid density. As the gas density varies greatly with the operating conditions, the calculation of the working density is required. The table below is the calculation method for setting different gas

densities.

【Note 4】 :

$$Q_{\text{heat}} = K_{\text{heat}} * Q * H$$

Where:

Q_{heat} : Heat flow rate

K_{heat} : Heat flow rate coefficient (The coefficient of enthalpy of this recorder is 1)

Q: Mass flow

rate H: Enthalpy

4.4. Accumulation setting

The accumulation function accumulates selected signal sources in terms of hour, day, and month, which forms a time report, a daily report, and a monthly report.

Configuration Item Description:

configuration Item	Function Description	Parameter range
Channel	Select the accumulated channel	ACC1~ACC4
Status	Enable/Disenable this channel	Enable/Disenable
Unit	Unit displayed in accumulation interface	User-defined 8-bit character string
Signal source	Channel to be accumulated	AI1~AI18 FLOW1~FLOW4 【Note 1】
Compensation mode	Calculation method	Applicable fluid
Given density	Calculate as per given density	Liquid
Superheated steam	Calculate as per IAPWS-IF97	Superheated steam
Saturated steam P	Calculate through pressure as per IAPWS-IF97	Saturated steam
Saturated steam T	Calculate through temperature as per IAPWS-IF97	Saturated steam
General gas	Calculate as per ideal equation, a standard density is required.	Oxygen, nitrogen, hydrogen, etc
Without compensation	Calculate as per constant 1	Measure volume flow rate
Temperature linear compensation	$\rho = A + B * t$, A, B are linear compensation coefficients	
Pressure linear compensation	$\rho = A + B * P$, A, B are linear compensation coefficients	

Accumulation multiplying power	Multiply by multiplying power	0~99999
Accumulated initial value	Initial value at restoration	0~999999
Eliminate accumulated value	Reset this channel according to accumulated initial value	【Note 2】

【Note 1】 : When mode AO or remote Modbus input is selected, only AI1~AI12 is available.

【Note 2】 :After modifying the accumulated initial value, it requires to enable the configuration again to make it effective.

4.5.Control setting

4 PID single loops are provided under PID control mode.

Configuration Item Description:

configuration Item	Function Description	Parameter range
Channel	Select PID channel to be set	PID1~PID4
Status	Enable/Disable this channel	Enable/Disable
Measurement value	Measurement value of PID calculation	AI1~AI12
Setting value	Setting value of PID calculation	None, AI1~AI12
P (%)	P in PDI calculation	0.0~9999.9
I (s)	I in PDI calculation	0.0~9999.9
D (s)	D in PDI calculation	0.0~9999.9
Control cycle	PDI calculation cycle	1s、2s、5s...60min
positive and negative effect	Positive and negative effect of PDI	Positive effect
SVH (%)	Upper limit of setting value	0.00~100.00
SVL (%)	lower limit of setting value	0.00~100.00
MVH (%)	Output upper limit	0.0~100.0
MVL (%)	Output lower limit	0.0~100.0
DMV (%)	Max. value of output variation at a single cycle	0.0~100.0
A/M initial value	Auto/manual initial value	Manual/Auto
L/R initial value	Internal/external given initial value	Internal/external given value
SV (%) initial value	Setting value and initial value percent	0.00~100.00
MV (%) initial value	Percent of output initial value	0.0~100.0

configuration Item	Function Description	Parameter range
A/M undisturbed switch	Undisturbed Manual/Auto switch	Enable/Disenable
Faultoutput	Output action in case of abnormal input signal	MVH、MVL、MV initial value

4.6.Function setting

4. 6. 1. Zero clearing

Configuration Item Description:

configuration Item	Function Description
Clear log record	Clear all log records
Clear accumulated report	Clear all accumulated reports
Clear power loss record	Clear all power loss records
Clear alarm information	Clear all alarm information

4. 6. 2. U disk operation

The instrument supports saving the current configuration to a USB disk or reading the configuration file therein.

Configuration Item Description:

configuration Item	Function Description	File format
Save recorder configuration	Save current recorder configuration	CFG (.cfg)
Read recorder configuration	Read recorder configuration in U disk NOTE: The recorder configuration is scanned when the U disk is inserted. The newly saved configuration can merely be displayed when U disk is inserted and plugged for once.	
Save log records	Save log records	

4. 6. 3. Communication setting

This product supports communication operation with a host computer (the matched host computer can be obtained in our WeChat official account/official website), thereby realizing real-time monitoring of the instrument. This product only supports Modbus protocol.

Configuration Item Description:

configuration Item	Function Description	Parameter range
Instrument address	Modbus Device Address	1~254
Baud Rate	Communication speed	1200,9600,57600,115200
Parity bit	Communication verify	No parity, odd parity, even parity
Floating-point format	Floating point format	1234,2143,3412,4321

4. 6. 4. Remote setting

The remote input module can read the Modbus channel through the RS-485 terminal on the current board .It supports a maximum of 6 channels.

Configuration Item Description:

configuration Item	Function Description	Parameter range
Status	Functional switch for remote input	Enable/Disable
Baud rate	Baud rate of serial port data	1200、9600、57600、115200
Check bit	Check bit of serial port data	No parity check, odd parity check, even-parity check
Channel 1		
Device address	Device address for the first remote channel	0-254, 0 indicates a close channel
Register address	Register address for the first remote channel	1~65535
Floating point format	Data format	F1234、F2143、F3412、F4321、L1234、L4321 【Note1】
Smoothing time	Average value smoothing	0s、1s、2s...30s
Correction factor A	A in $Y=A*X+B$	-99999~99999
Correction factor B	B in $Y=A*X+B$	-99999~99999
Channel 2		
Device address	Device address for the second remote	0-254, 0 indicates a close channel
Register address	Device address for the second remote	1~65535
Floating point format	Data format	F1234、F2143、F3412、F4321、L1234、L4321 【Note 1】
Smoothing time	Average value smoothing	0s、1s、2s...30s
Correction factor A	A in $Y=A*X+B$	-99999~99999
Correction factor B	B in $Y=A*X+B$	-99999~99999
Channel 3		
Device address	Device address for the third remote channel	0-254, 0 indicates a close channel

configuration Item	Function Description	Parameter range
Register address	Device address for the third remote channel	1~65535
Floating point format	Data format	F1234、F2143、F3412、F4321、L1234、L4321 【Note 1】
Smoothing time	Average value smoothing	0s、1s、2s...30s
Correction factor A	A in $Y=A*X+B$	-99999~99999
Correction factor B	B in $Y=A*X+B$	-99999~99999
Channel 4		
Device address	Device address for the fourth remote channel	0-254, 0 indicates a close channel
Register address	Device address for the fourth remote channel	1~65535
Floating point format	Data format	F1234、F2143、F3412、F4321、L1234、L4321 【Note 1】
Smoothing time	Average value smoothing	0s、1s、2s...30s
Correction factor A	A in $Y=A*X+B$	-99999~99999
Correction factor B	B in $Y=A*X+B$	-99999~99999
Channel 5		
Device address	Device address for the fifth remote channel	0-254, 0 indicates a close channel
Register address	Device address for the fifth remote channel	1~65535
Floating point format	Data format	F1234、F2143、F3412、F4321、L1234、L4321 【Note 1】
Smoothing time	Average value smoothing	0s、1s、2s...30s
Correction factor A	A in $Y=A*X+B$	-99999~99999
Correction factor B	B in $Y=A*X+B$	-99999~99999
Channel 6		
Device address	Device address for the sixth remote channel	0-254, 0 indicates a close channel
Register address	Device address for the sixth remote channel	1~65535
Floating point format	Data format	F1234、F2143、F3412、F4321、L1234、L4321 【Note 1】
Smoothing time	Average value smoothing	0s、1s、2s...30s
Correction factor A	A in $Y=A*X+B$	-99999~99999
Correction factor B	B in $Y=A*X+B$	-99999~99999

【Note 1】:F1234、 F2143、 F3412、 F432 is a single precision floating-point number of 4 bytes.L1234、 L4321 is the 4-byte integer

Use of remote channel

Step	Interface	Operation
1		<input type="checkbox"/> Select Remote1~Remote6 in the Signal configuration under Input Setting, which corresponds to remote channel 1-6, namely allowing display, alarm and record signal of same analog quantity.

4. 6. 5. User-defined screen

configuration Item	Function Description	Parameter range
Channel 1	Define the first channel	AI、 FLOW
Channel 2	Define the second channel	AI、 FLOW
Channel 3	Define the third channel	AI、 FLOW
Channel 4	Define the fourth channel	AI、 FLOW
Channel 5	Define the fifth channel	AI、 FLOW
Channel 6	Define the sixth channel	AI、 FLOW

4.7.System Settings

Configuration Item Description:

configuration Item	Function Description	Parameter range
Password	Set password	000000~999999
recorder name	Set recorder name	8-bit character string
System time	Set recorder time	
Time format	Set time display	YY-MM-DD、 DD-MM-YY、 MM-DD-YY
record interval	Set record interval	1s、 2s、 5s...60min(One second can be recorded for 10 days)
Curve coordinate	Set curve coordinate	Percent and engineering quantity
Language	Select system language	Chinese/English

configuration Item	Function Description	Parameter range
Starting up interface	Set the default starting up interface	General interface, digital display interface, historical interface, flow interface, cumulative flow, real-time curve.
Cycling time	Display cycling time by group	0s、5s、10s、30s
Atmospheric pressure MPa	Set the atmospheric	-100000000~100000000
Reset default configuration	pressure of the recorder	

Configuration item	Function Description	Parameter range
Supplier password	Set supplier password	000000~999999
Acquirer password	Set acquirer password	000000~999999
Instrument name	Set instrument name	Strings of 8 bytes
System time	Set system time	
Time format	Set time format	YY-MM-DD, DD-MM-YY, MM-DD-YY
Recording interval	Set recording interval	1s, 2s, 5s, 10s, 15s, 30s, 1s, 2s, 5s, 10s, 30s, 60s
Startup screen	Set the default startup screen.	Front Panel ,digital display screen, history screen
Cycle Time	The screen displays the cycle time of grouping	0s、5s、10s、30s
Atmospheric pressure MPa	Set the Atmospheric pressure of the instruments	-999999~999999
Restore factory configuration	Restore factory configuration	

Appendix 1: Address and Examples of Modbus

Address table of Modbus:

Number	Parameter	Types of parameter	Starting address of register (decimal)	The number of
1	No.1 channel analoginput	Floating pointtype	1	2 registers
2	No.2 channel analoginput	Floating pointtype	3	2 registers
3	No.3 channel analoginput	Floating pointtype	5	2 registers
4	No.4 channel analoginput	Floating pointtype	7	2 registers
5	No.5 channel analoginput	Floating pointtype	9	2 registers
6	No.6 channel analoginput	Floating pointtype	11	2 registers
7	No.7 channel analoginput	Floating pointtype	13	2 registers
8	No.8 channel analoginput	Floating pointtype	15	2 registers
9	No.9 channel analoginput	Floating pointtype	17	2 registers
10	No.10 channel analoginput	Floating pointtype	19	2 registers
11	No.11 channel analoginput	Floating pointtype	21	2 registers
12	No.12 channel analoginput	Floating pointtype	23	2 registers
13	No.13 channel analoginput	Floating pointtype	25	2 registers
14	No.14 channel analoginput	Floating pointtype	27	2 registers
15	No.15 channel analoginput	Floating pointtype	29	2 registers
16	No.16 channel analoginput	Floating pointtype	31	2 registers
17	No.17 channel analoginput	Floating pointtype	33	2 registers
18	No.18 channel analoginput	Floating pointtype	35	2 registers

No.	Parameter	Parameter type	Initial address of register (Decimalism)	Register number
1	Flow of the first channel	Parameter type	2001	2 registers
2	Flow of the second channel	Parameter type	2003	2 registers
3	Flow of the third channel	Parameter type	2005	2 registers
4	Flow of the fourth channel	Parameter type	2007	2 registers

No.	Parameter	Parameter type	Initial address of register (Decimalism)	Register number
1	Accumulated Flow of the first channel	Integer	4001	2 registers
2	Accumulated Flow of the second channel	Integer	4003	2 registers
3	Accumulated Flow of the third channel	Integer	4005	2 registers
4	Accumulated Flow of the fourth channel	Integer	4007	2 registers

No.	Parameter	Parameter type	Initial address of register (Decimalism)	Register number
1	Accumulated Flow of the first channel	Parameter type	5001	2 registers
2	Accumulated Flow of the second channel	Parameter type	5003	2 registers
3	Accumulated Flow of the third channel	Parameter type	5005	2 registers
4	Accumulated Flow of the fourth channel	Parameter type	5007	2 registers

Communication Example:

Example 1: Real-time value of analog input 2

State:

Explanations : 06030003000235BC

06: instruments address (Configuration can be changed)

03: 03 order to Modbus

00 03: Address 3 of register

00 02: The number of registers is 2

35BC: CRCVerify

Returned data: 01 03 04 42 C8 00 00 6F B5 Explanations:

01: Instruments address 03:

03 order to Modbus 04: Four

bytes of returned data

42 C8 00 00: Floating point(F4321, configuration can be modified), It represents 100.0

6F F5: CRC Verify

Appendix 2: Calculation of flow coefficient K

Case 1: Orifice (no extraction of a root for differential pressure), measure the flow of oxygen in Nm³/h.

Calculation sheet

<u>process data:</u>	design	max	norm	min	Einheit
absolute pressure	950.000				kPa
temperature	20.0				°C
Flow expansion coefficient	40000.00000	36000.00000	21500.00000	10800.00000	Nm ³ /h
reynolds	0.9994	1.0000	0.9998	0.9995	-
fluid velocity	278E+04	25,009E+02	14,936E+02	75,026E+01	-
pressure loss differential	12.3963	11.1567	6.6630	3.3470	m/s
pressure	0.1066	0.0863	0.0308	0.0078	kPa
	1.8400	1.4901	0.5312	0.1340	kPa

Obtain the following information based on the calculation sheet:

parameter	Value
Design pressure	0.95MPa
Design temperature	20°C
Design flow	40000Nm ³ /h
Design differential pressure	1.84kPa

Calculation method:

The oxygen density under standard conditions and design temperature pressure are calculated.

According to the ideal state equation:

$$PV = nRT \quad (mRT/M)$$

$$PV = mRT/M$$

$$PM/RT = m/V$$

$$\rho = PM / RT$$

The density under standard conditions is 1.429Kg/m³.

The density under design temperature pressure is 12.485Kg/m³.

Calculate according to the formula $Q = K \cdot \sqrt{P^*}$, which is substituted by design parameters.

$$40000 = K \cdot \sqrt{1.84 \cdot 12.485}$$

$$K = 11926.1$$

Special explanation:

Since the designed flow unit is Nm³/h, first, convert the designed flow unit into standard unit. The flow unit obtained at this time is Kg/h. If you want to acquire t/h, you need to reduce K by 1000 times to 11.9261. If you want to acquire Nm³/h, you need to use K to divide by the density under standard conditions 1.429 to obtain 8345.7.