

**Fixed Gas Detector
YT-95H-:XX
Instruction Manual**



Notice to Reader

Please read this instruction manual before using the detector

Matters need attention

- A. Please read this instruction manual before using the detector.
- B. The detector must be used in compliance with the designated procedures of our company.
- C. The warranty period of this transmitter is 12months (starts from the date userget the detector). Users should comply with the instructions in the use of this detector. Any damages or malfunctions caused by improperoperation of users are not within the scope of warranty.
- D. Repairand replacement of any parts must be operated by trained staff under authorization of our company, using original spare part. The operatoris responsible for the liability if users operate the repair of replacement by themselves.
- E. There is acid solution inside the transmitter, please do not disassembleit. And pay attention not to damage the frontal membrane of the transmitter. If the skin is stained with the acid solution, the right remedy is to flushing the stained skin continuously with clean water for 1 0minutes.
- F. The detector must be calibrated for once each year. The explosion proof sheet parts of the transmitter need to be cleaned regularly (blow with low pressure compressedair), otherwise the detection sensitivity will be affected by the dust and impurities clogging protection hole.

Port Instruction

- 1. Power supply, signal line
- 2. Printed-circuit board
- 3. Terminal
- 4. Sound and tight alarm port
- 5. Air chamber of sensor
- 6. Sensor port
- 7. Main board connection

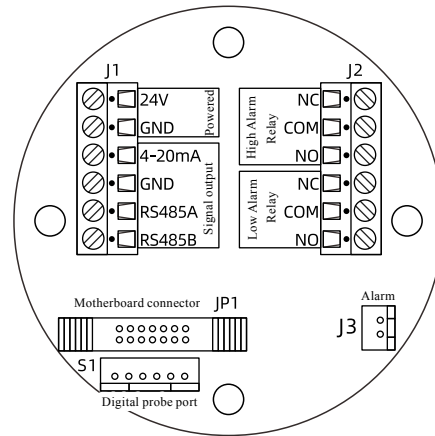
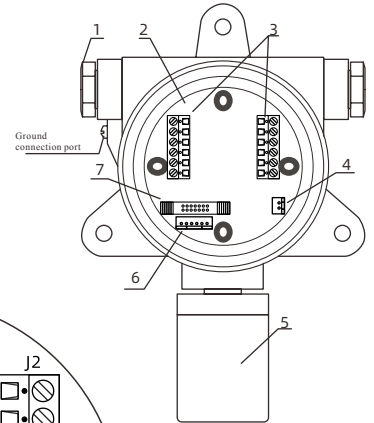

NC:Normally close
NO:Normally open
COM:Common
24V:24+,positive
GND:24-,negative
4~20mA:4~20mA analog signal

Technical performance and parameters

1. Key Technical Indicator

| Target gas | Range | Accuracy | least count | response time |
|---------------------------------|------------|-----------|-------------|---------------|
| O ₂ | 0-30%VOL | <±2%(F.S) | 0.01%VOL | ≤15 |
| H ₂ S | 0-1000ppm | <±2%(F.S) | 1ppm | ≤15 |
| CO | 0-1000ppm | <±2%(F.S) | 1ppm | ≤25 |
| H ₂ | 0-20000ppm | <±2%(F.S) | 1ppm | ≤15 |
| CO ₂ | 0-10000ppm | <±2%(F.S) | 1ppm | ≤40 |
| C ₂ H ₄ | 0-100ppm | <±2%(F.S) | 0.01ppm | ≤60 |
| NO ₂ | 0-20.0ppm | <±2%(F.S) | 0.1ppm | ≤25 |
| N ₂ | 0-100%VOL | <±2%(F.S) | 0.01%VOL | ≤40 |
| TVOC | 0-6000ppm | <±2%(F.S) | 1ppm | ≤60 |
| NH ₃ | 0-100ppm | <±2%(F.S) | 0.01ppm | ≤40 |
| ASH ₃ | 0-10.00ppm | <±2%(F.S) | 0.01ppm | ≤30 |
| C ₃ H ₃ N | 0-200.0ppm | <±2%(F.S) | 0.1ppm | ≤40 |
| F ₂ | 0-10 ppm | <±2%(F.S) | 0.01ppm | ≤25 |
| O ₃ | 0-5.00ppm | <±2%(F.S) | 0.01ppm | ≤50 |
| CL ₂ | 0-10.00ppm | <±2%(F.S) | 0.01ppm | ≤60 |
| BF ₃ | 0-10.00ppm | <±2%(F.S) | 0.01ppm | ≤60 |

Repeatability: <2%
Zero drift: <± 2% (F•S) /6M
Operating temperature: -20~+50°C
Environment temperature: <90%RH

Working principle of the transmitter: electrochemical for oxygen and hazardous gases, catalytic combustion for combustible gases
Lifespan of transmitter: 3years for combustible gas transmitter; 2years for hazardous gas transmitter

2. Other Technical Parameters

Inspection mode: diffusion
Working mode: fixed long-term continuous work
Working voltage: 12-30V DC
Working current: oxygen and hazardous gas <50mA (Max)
combustible gas <150mA (Max)

Output signal: three-wire 4-20 mA standard signal output or RS485 signal output
Exterior structure: die-casting aluminum housing
Dimensions: 135 x 125 x 116mm (without mounting bracket)
167 x 145 x 126mm (with bracket)
Weight: without mounting brackets 1.2kg with brackets 1.6kg with stent

Connection cable (6 core cable) is defined as follows:

4-20mA with RS485:
Red: positive-input of power (12 to 24V)/ 24V+
Black: ground wire of power/24V
Yellow:4-20mA output.
Orange: RS485A
Blue: RS485B
Brown: Free
Connection distance: >1000m
Protection grade: IP65
Installation type: on wall
Type of explosion-proof: flame proof
Explosion-proof grade: Ex d IIC T6 Gb
Inlet port: hexagonal locknut

Settings of Remote Control

- The remote control applied to all product type produced by Yuante.
1. Press "MENU" once to enter F01, address code setting menu. Press "OK" to modify, press "+" "-" to modify address code of the detector. Press "OK" to save settings and "BACK" to cancel.
 2. Press "MENU", then press "+" to enter F02, minimum value setting menu of gas alarm, Press "OK" to modify, press "+" "-" to modify the value. Press "OK" to save settings and "BACK" to cancel.
 3. Continue to press "+" to enter F03, maximum value setting menu of gas alarm., Press "OK" to modify, press "+" "-" to modify the value. Press "OK" to save settings and "BACK" to cancel. Same operation with F04 (zero point calibration), F05 (range calibration), F06 (AD value).
 4. Press "MENU" four times to enter a shift status, under this status:
Press "RESET" once, the data would be 255, one more it would be 0. Just press "RESET" to shift. When the data is 0, press "+" or "-" to modify alarm point, the data difference would be only 1. When the data is 255, press "+" or "-" to modify alarm point, the data difference would be 1000. "RESET" can also be used as mute button when it is alarming.

Remote controller function

| | |
|-------|---|
| MENU | MENU button, from the measurement state into the functional state |
| RESET | alarm reset to eliminate alarm function |
| OK | confirm button |
| + | plus |
| BACK | return |
| - | minus |

Function introduction

Controller function introduction

- F-01 Address, Range1-200
- F-02 Low point alarm
- F-03 High point alarm
- F-04 Zero calibration
- F-05 4mA offset correction
- F-06 ADC check
- F-07 Standard gas concentration
- F-08 Calibration switch
- F-09 Production date
- F-10 Reserved function
- F-11 Serial communication check. 0 no check, 1 odd check, 2 even check
- F-12 Arrangement mode of the floating-point data
- 0:DCBA
- 1:ABCD
- 2:CDAB

Need to press OK to save after all the above parameters are modified, which can take effect immediately, power outage restart also valid.

Installation Instruction

1. Location Selection

The location selection of the gas detection transmitter is essential to achieve the best detection results. In the selection of location, we need to consider the following factors: the density of gas in a leaking point, proportion of target gas, the impact of surrounding buildings, condition of production equipment, wind direction and annual meteorological conditions and even the location of windows and doors in an indoor environment.

We provide the following suggestions for your reference:

- A. Maintain a proper distance between the detector and the possible gas leaking point. It would react too fast or too frequent if the distance is not enough, which may paralyze people's mind.
- B. The detector must be located in the downwind of the possible leaking point.

- C. If installed indoor, but the source of the leak is outdoor, the detector must be installed at the air inlet.
- D. Determine the height according to proportion of target gas in air.
- E. Determine the quantity of detectors according to the condition of possible leaking point, frequency of staff attendance and time of stay as well as the economic effect.
- F. Consider to increase quantity of inspection point if the equipment is old.
- G. Protect the detector from radiation of high temperature heat source. Environments of both very high temperature and very low temperature will affect the result and lifespan of the detector.

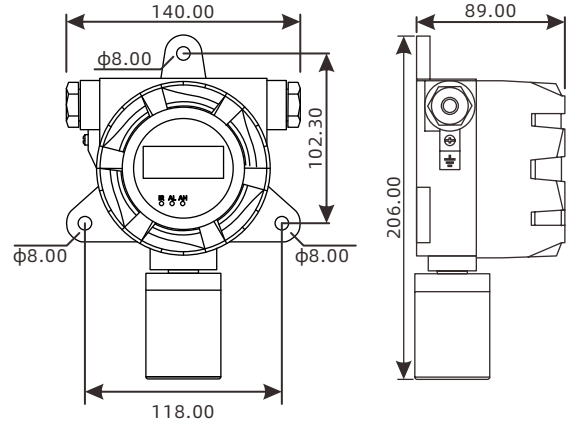

2. Steps of Installation

Connect wire to correspondent terminals. Don't work with power on. The arrangement of terminals differs according to the type of transmitter. The definition of different wires:

- Red: positive-input of power (12 to 24V)/24V+
- Black: ground wire of power/24V
- Yellow:4-20mA output.
- Orange: RS485A
- Blue: RS485B
- Brown: Free

Fix the detector on the wall with expansion bolt, make sure the transmitter is downward, or the detector cannot work properly. Users can also separate the bracket and transmitter according to the condition on spot, fix the bracket before connection.

For the sake of safety and interference reduction, please connect the housing with reliable ground wire. For the wire between the transmitter and the main engine, the shorter, the better. And protect the wire with iron pipe.

Method of Calibration

To guarantee the measurement accuracy of the transmitter, regular calibration and maintaining rigorous record is necessary.

Devices needed for calibration: a bottle of sample gas used for range calibration (60%F.S standard gas in normal site),relief valve, flow meter of 0-1000ml/min, transparent and smooth conduit for gas, standard gas housing, digital multimeter, stopwatch and etc.

Note: The value of transmitter WB (4mA) , WC (20mA) , Wz (zero potentiometer), WA (range potentiometer, also known as calibration potentiometer) and host alarm has been set right before it leaves the factory. User should not adjust casually. It is the value of zero potentiometer (Z) and calibration potentiometer (S) needed to be set on spot.

1. Zero Point Calibration

Open the detector in clean air, if there is readings after counting down.

Press the button "MENU" of the remote controller, the detector displays "F-01", press "+" or "-", change the function to "F-04", and click "OK". The detector value will be displayed as 0.

In the zero calibration of oxygen detection transmitter, we must use nitrogen of purity over 99.99%.

2. Range Calibration

1. Enter into "F-07" as the same way above. The "F-07" value is the concentration of the standard gas, initialized to half of the measure range. This value can be modified through the "+" and "-" keys to make it consistent with the standard gas concentration which need to be calibrated. Press "OK" to exit.

2. Enter into "F-08" to change 0 into 1, then back to detection interface.

3. Connect the 200-400mL/min standard gas in detection interface, when the detector value is stable, press "OK" for 3 seconds, then the instrument will be calibrated automatically. The measured concentration value is consistent with the value set in "F-07".

4. After calibration, left the detector in the air for a while. Shut off the power when the detector value is close to zero.

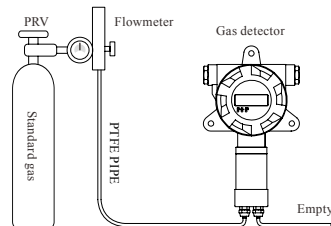

Common Malfunction, Repair and Maintenance

| Symptom | Reason | Method to process |
|---------------------------|---|---|
| No output for transmitter | wrong connection | connect again |
| | potential in reference point is not correct | Adjust zero point gradually and then adjust potentiometer (4mA) |
| | Circuit fault | Return to Yuante for repair |
| Too low host reading | Value of S potentiometer setting is too small | Calibrate again |
| | Transmitter failure | Get a new transmitter |
| Too high host reading | Value of S potentiometer setting is too large | Calibrate again |
| | Transmitter failure | Get a new transmitter |
| Instable host reading | Heat settling time is not enough | Wait for starting up |
| | Transmitter failure | Get a new transmitter |
| | Circuit fault | Return to Yuante for repair |

Product component

| | |
|---------------------------|-----|
| Fixed Gas Detector | one |
| Instruction Manual | one |
| Qualification Certificate | one |
| Remote Control | one |