



Differential Pressure Transmitter User Manual

Table of Contents

Precautions

1. Overview	2
2. Product Specifications	2
3. Dimensions	3
5. Function Description	7
6. Power-On Information	9
7. Electrical Connections	10
8. Installation Method	10
9. Unpacking Inspection	15



Precautions

1. After receiving the product, please check whether the packaging is intact and verify that the product model and specifications match your order.
2. Install and wire the product correctly and securely according to the provided process connections, electrical connections, and installation method.
3. This product is powered by a 24V DC supply.
4. During use, please observe the product's technical specifications and operating conditions, such as allowable medium temperature, overload pressure, and supply voltage.
5. This product is a precision device. Do not disassemble it yourself during use to avoid damage.
6. During installation, handle the product with care. Do not force installation or disassembly, as this may cause damage. After powering on, the device usually requires about 1 minute to start and enter the self-check program, which is normal.
7. If any abnormal condition occurs, please follow the troubleshooting steps in the manual or contact SISCO's after-sales technical support.
8. Installation stress may affect the product during installation. After installation, please perform zero calibration before use.
9. Installation, commissioning, and maintenance of this product should be carried out by qualified engineering and technical personnel.
10. If a malfunction or abnormality of this product may cause a major system accident, appropriate external protection circuits should be installed to prevent such incidents.
11. SISCO Company shall not be liable for any direct or indirect losses other than those related to the product itself.
12. SISCO Company reserves the right to modify this manual without prior notice.
13. Damage caused by non-professional operation not in accordance with the operating specifications is not covered under warranty.



1.Overview

1.The SISCO-DPG-WLC Differential Pressure Transmitter adopts a high-precision differential pressure sensor combined with digital technology to accurately display real-time differential pressure. It features high accuracy and excellent long-term stability.

2.This product uses a unique embedded installation method, making installation convenient, secure, and aesthetically pleasing. It is suitable for applications such as cleanroom engineering, building automation, and HVAC equipment.

The product is equipped with an LCD display for clear readings. The housing is made of ABS injection molding, offering good impact resistance and heat resistance.

2.Product Specifications

- Pressure Range: (-4 ~ 4) kPa (see selection table for details)
- Type: Embedded installation, face-mounted installation
- Overload Capacity: Depending on range (1, 2, 3, 4): overload 5×FS, burst pressure 10×FS
- Accuracy: ±1% FS
- Long-term Stability: 0.2% FS/year
- Power Supply: 24V DC
- Operating Temperature: -20°C ~ 80°C
- Operating Humidity: <80% RH
- Interface: Push-in hose connection
- Power Consumption: <0.5 W
- Display: 5-digit LCD or without display
- Measured Media: Air and non-corrosive gases
- Housing Material: PC/ABS
- Protection Rating: IP54
- Weight: 200 g

3.Dimension Drawing

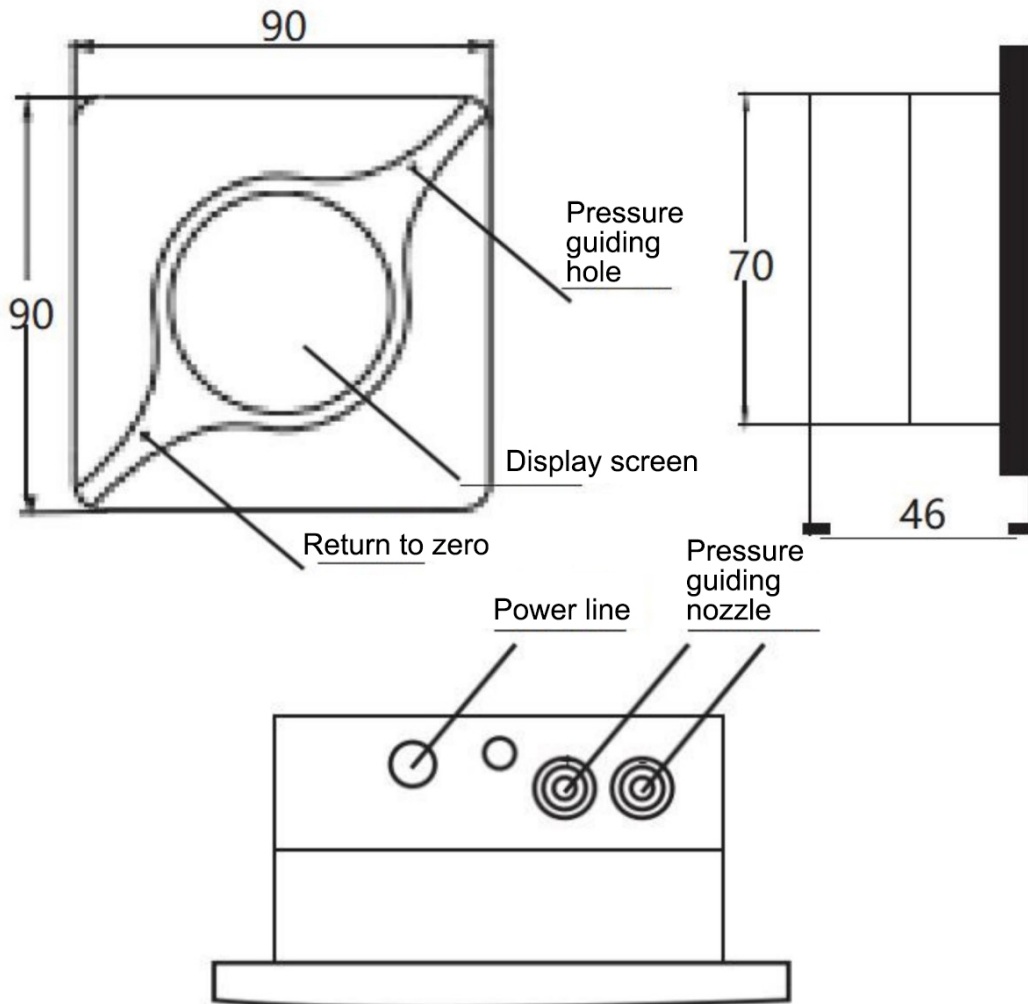

(Figure 1) Embedded display type external dimensions diagram in mm

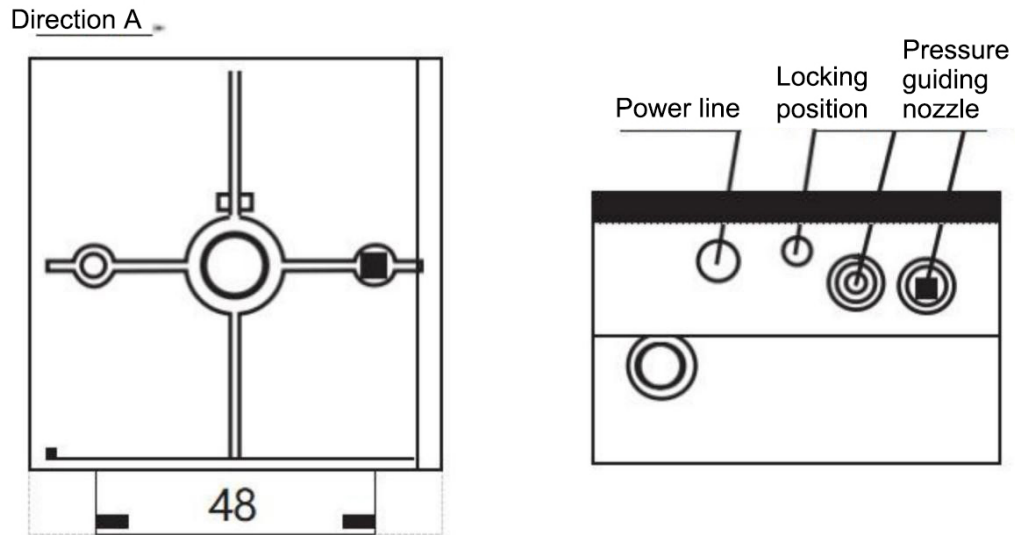
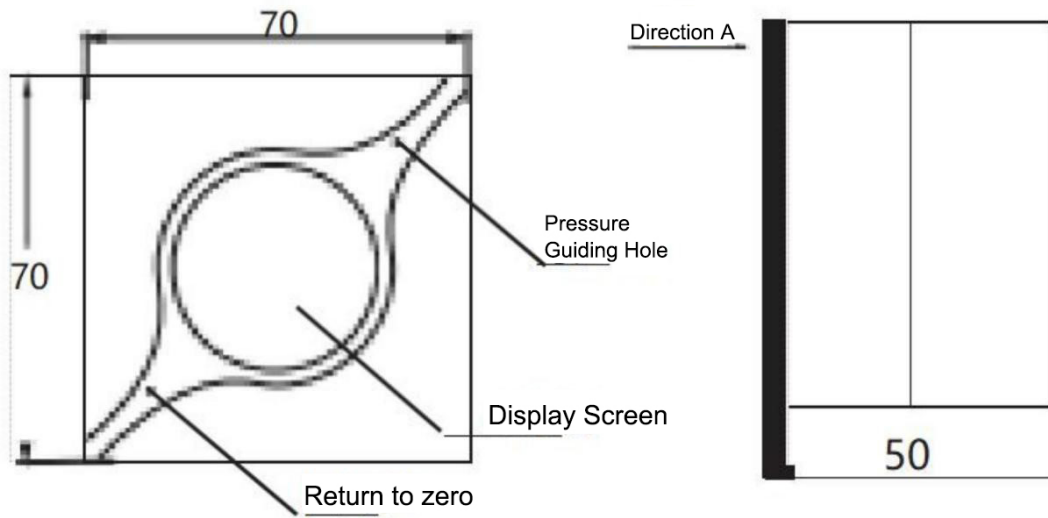

(Figure 2) Installation external dimensions of the end face display type in mm

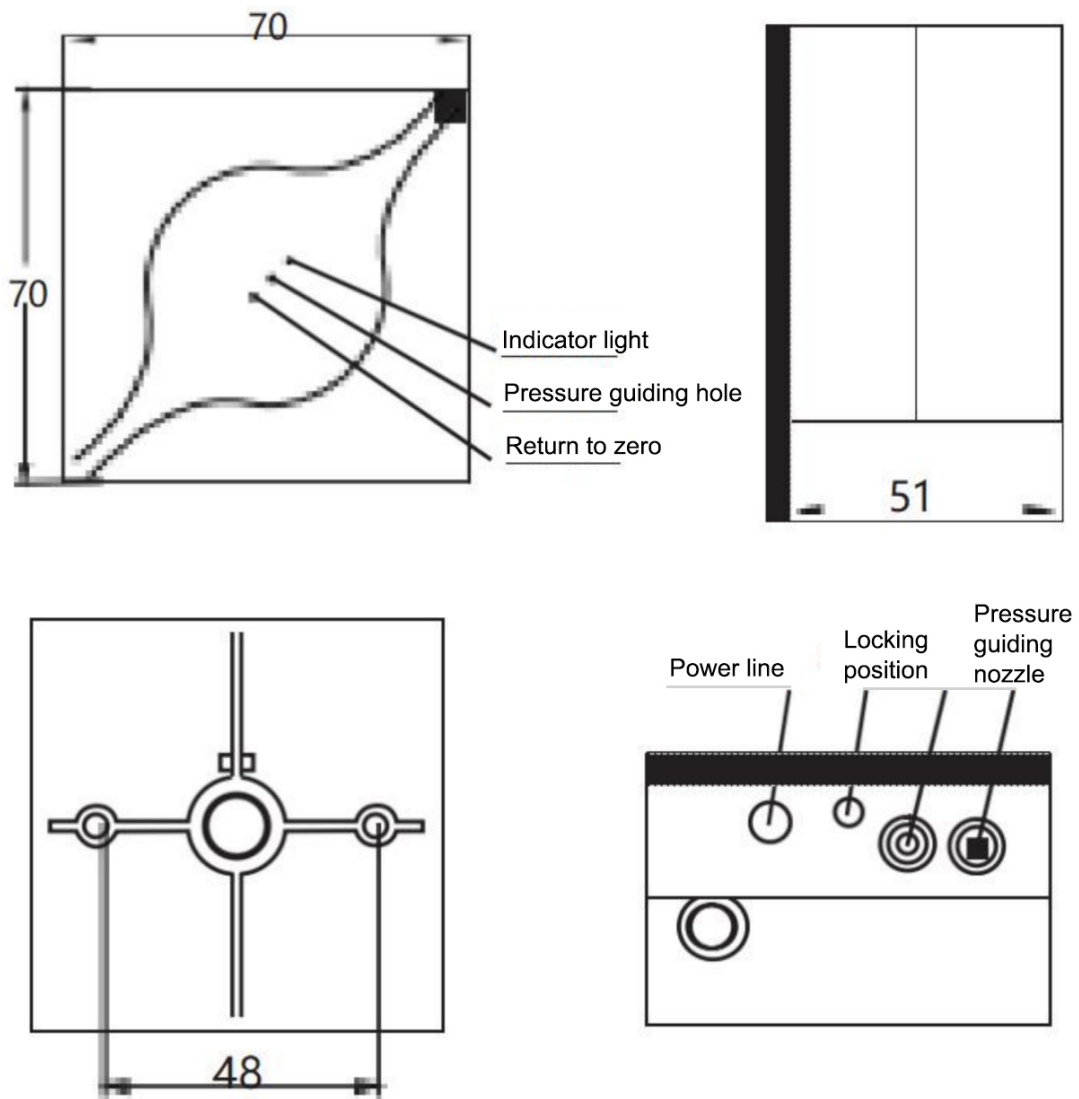

(Figure 3) Installation Dimensions for Flange-Mounted, Non-Display Type (mm)

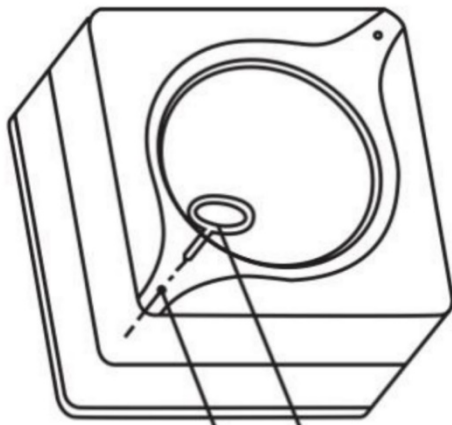

Return to zero

Insert a needle

(Figure 4)

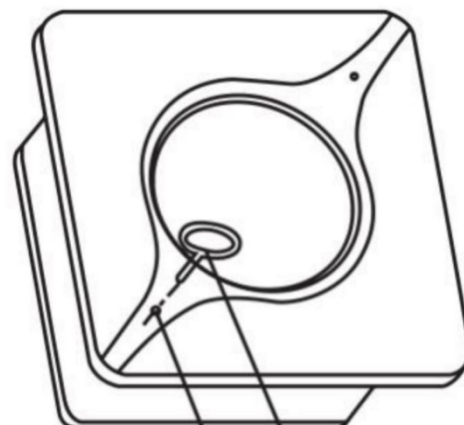

Return to zero

Insert a needle

(Figure 5)

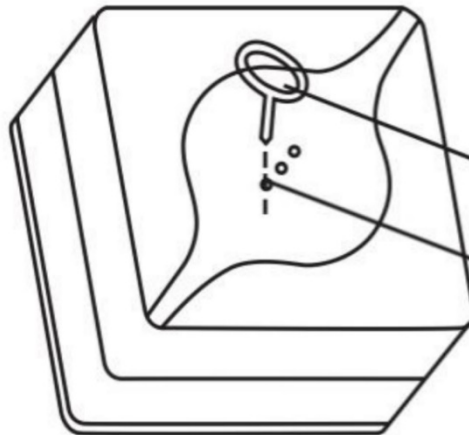

Insert a needle

Return to zero

(Figure 6)

(Figures 4, 5, and 6) Diagrams showing the zero-adjustment procedure

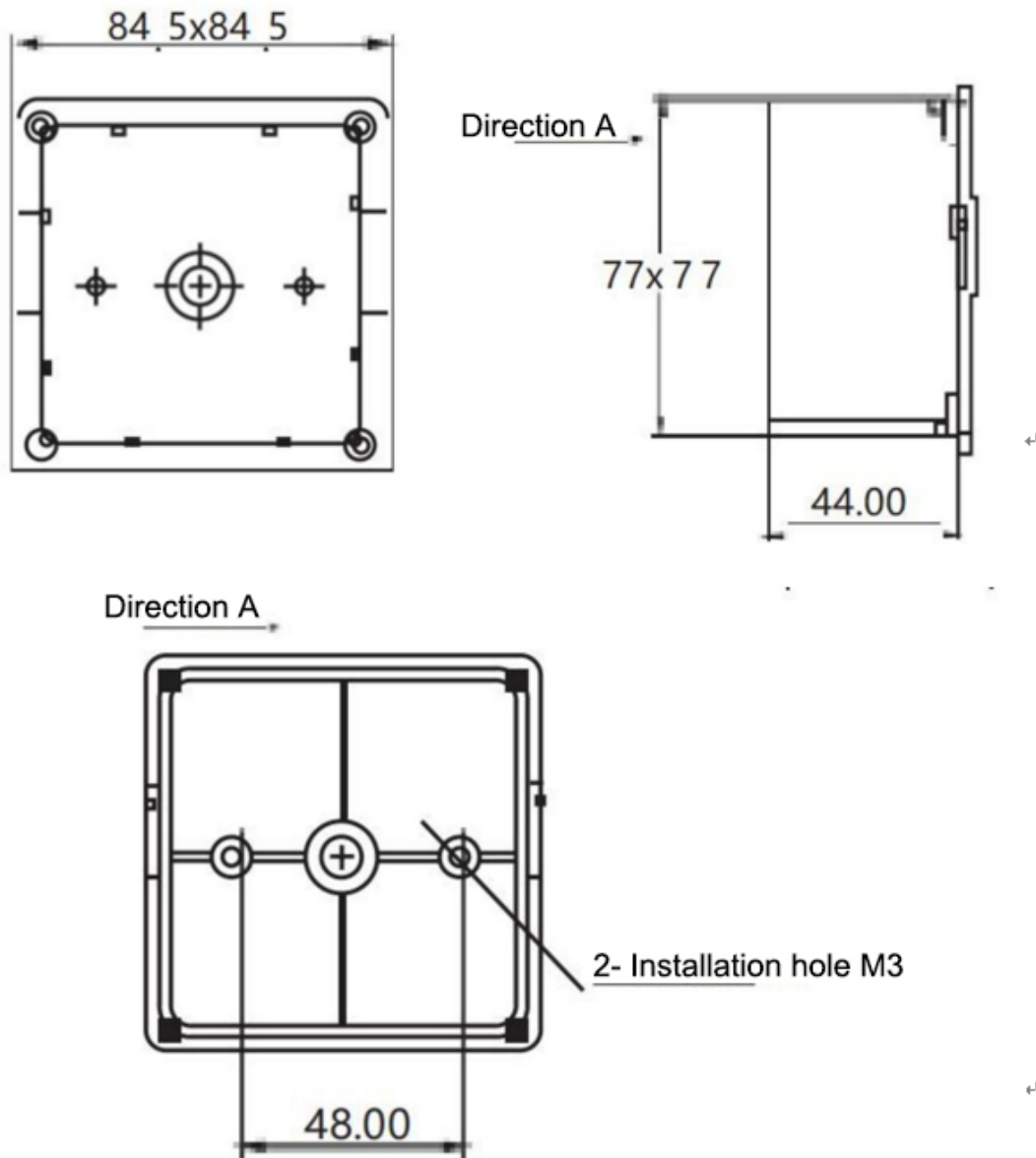

(Figure 7) Dimensions of the embedded installation base box in mm

4.Power-on Information

Set the sequence

Setting Sequence

Power On → Self-check Mode → Zero Calibration → Function Setting → Measurement Mode

After power-on, the device automatically enters the self-check program, and the screen displays the instrument range information.



1. Zero Calibration (Display Version)

When the device is powered on and no pressure is applied, if the displayed value is not zero, use the supplied pin tool to press the pinhole button [Zero Reset] located at the lower left corner of the front panel. Press and hold for more than 5 seconds until “ZERO” is displayed. Press the button again, and “GOOD” will be displayed, indicating successful calibration and zeroing.

2. Zero Calibration (Non-display Version)

When the device is powered on and no pressure is applied, if the output value (4–20 mA current or voltage) does not correspond to 0 Pa, use the supplied pin tool to press the pinhole button [Zero Reset] at the lower left corner of the front panel. Press and hold for 5 seconds, then release the button; the indicator light will flash once. Press the button again for 1 second, and the indicator light will flash three times, indicating successful zero calibration.

3. Restore Factory Settings

Loosen the locking screw at the top center on the back of the transmitter and open the rear cover. Press and hold the (right) RST button for 10 seconds, then release it. “PSET” will be displayed. Press the (right) RST button again, and “GOOD” will be displayed, indicating that the factory settings have been successfully restored. Press the (left) CLR button to cancel the operation.

4. External Indicator Light (Non-display Version)

When the zero reset button at the lower left is pressed, the indicator light at the upper right remains on; when released, the light turns off. The indicator flashes once every 5 seconds during normal operation. If the indicator does not light up, the device is not working—please check the power supply or other faults. If the indicator flashes at a frequency of once per second, it indicates an alarm output.

5. High Alarm Setting

Press and hold the (left) CLR button for 5 seconds, then release it. “H-AL” will be displayed. Press the (left) CLR button again to enter the high alarm setting. The (left) CLR button is used to shift positions, and the (right) RST button is used to adjust values cyclically. After setting the desired value, press the (left) CLR button to confirm.

6. Low Alarm Setting

Press and hold the (right) RST button for 5 seconds, then release it. “L-AL” will be displayed. Press the (right) RST button again to enter the low alarm setting. The (right) RST button is used to shift positions, and the (left) CLR button is used to adjust values cyclically. After setting the desired value, press the (right) RST button to confirm.

5. Power-on Information

No.	Display	Description	Example	For example
1	Uxxxx	Software version	U2001	2-Seven-Line Series 001 - Software Version
2	P-01xxxx	Positive Maximum Range	P-014000	Maximum positive range: 4000
3	P-02xxxx	Negative Full Scale Range	P-02-4000	Full-scale negative range: -4000
4	P-03xxxx	Positive maximum alarm value	P-03 20	The high alarm threshold is 20
5	P-04xxxx	Negative maximum alarm value	P-04-20	The low alarm threshold is -20
6	p-05xxxx	Terminal Address	P-05 1001	1xxx
				1 — Baud rate 9600
				2 — Baud rate 19200
				x001
				001 is the address number, max 256

6. Electrical Connections

Terminal Number	Corresponding Number	Pure Display	Relay	RS485	4 - wire Current/Voltage	2 - wire Current	Relay RS485	Relay Current/Voltage
Terminal	1	DC24V+	DC24V+	DC24V+	DC24V+	1+	DC24V+	DC24V+
Terminal	2	DC24V-	DC24V-	DC24V-	DC24V-	1-	DC24V-	DC24V-
Terminal	3			RS485A	1+/V+		RS485A	1+/V+
Terminal	4			RS485B	1-/V-		RS485B	1-/V-
Terminal	5		H-OUT				H-OUT	H-OUT
Terminal	6		C0M				C0M	C0M
Terminal	7		C0M				C0M	C0M
Terminal	8		L-OUT				L-OUT	L-OUT

Note: H-OUT: High-point alarm relay output (relay output is a dry contact); L-OUT: Low-point alarm relay output; C0M: Common terminal for high and low alarm points

7. Installation Method

- Panel (Embedded) Installation

1. After pressurization, the pressure display or output shows no change or incorrect variation.

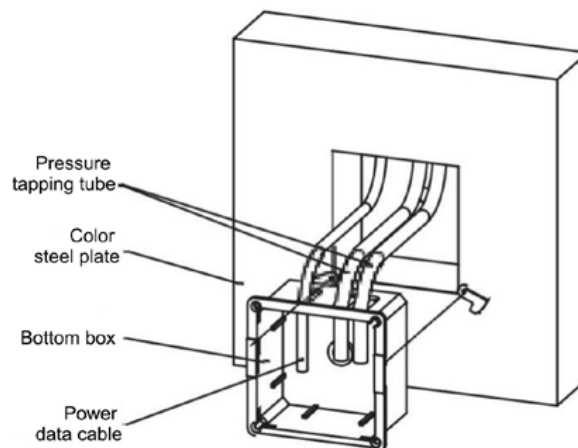

2. After pre-assembling the 4 base box locking plates and M3×5 countersunk headscrews, insert them into the color steel plate in the direction shown in the diagram. At the same time, press in the 2 locking plates as shown in the figure:

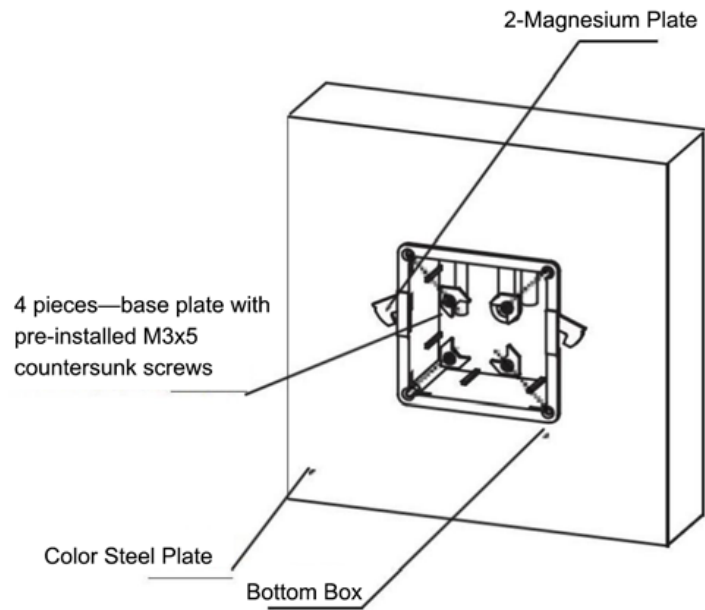

3. After the 4 base box locking plates and M3×5 countersunk head screws are properly positioned, press in the 2 locking plates simultaneously and tighten them.

Inspection:

1. The base box and color steel plate are evenly and firmly fitted.
2. The left and right locking plates are correctly installed in place.
3. The M3×5 countersunk head screws are flush after installation.

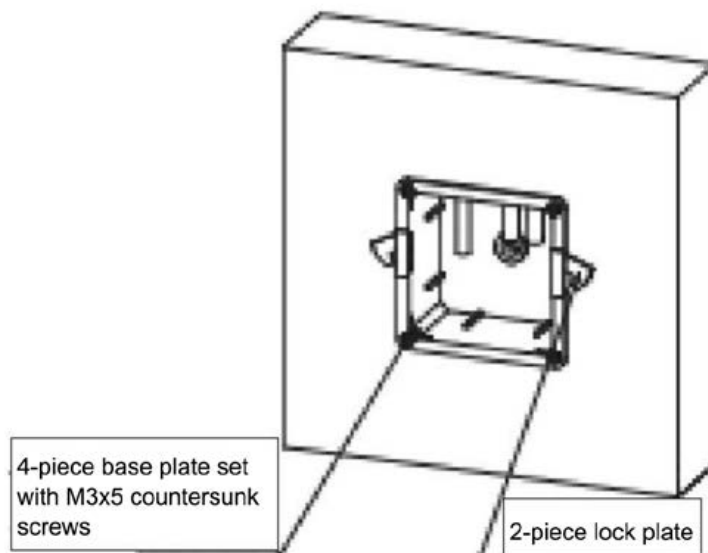

4. Connect the data cable as shown in the diagram. After securely installing the cable clamp plate, wire the connections as required.

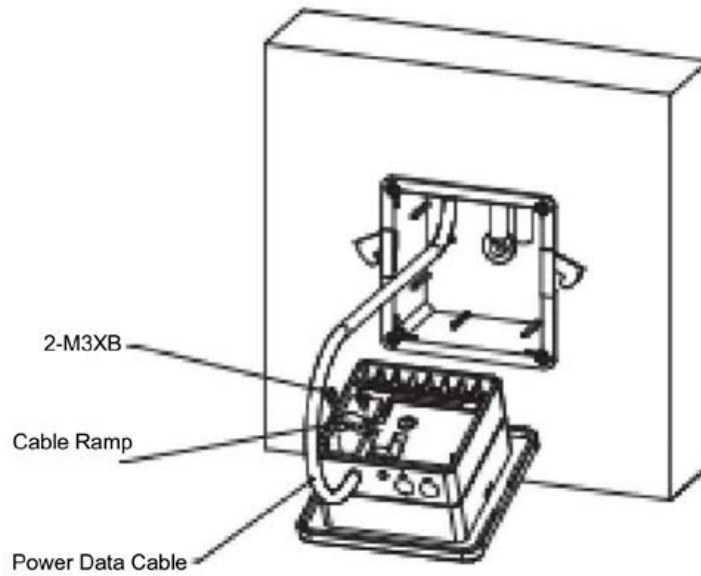

•Flush-Mount Installation

1. The base plate is shown in the figure and is fixed to the wall with 2-3mm self-tapping screws.

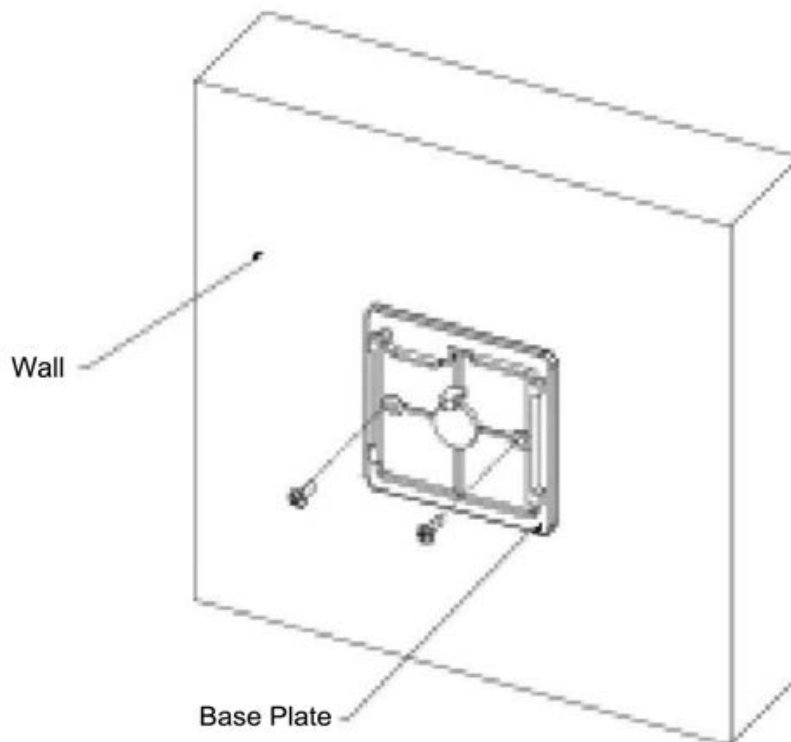

2. Connect the data cable as shown in the diagram. After securely installing the cable clamp plate, wire the connections as required. Adjust the bolts shown in Figure A until they are flush with the surface in Figure B.

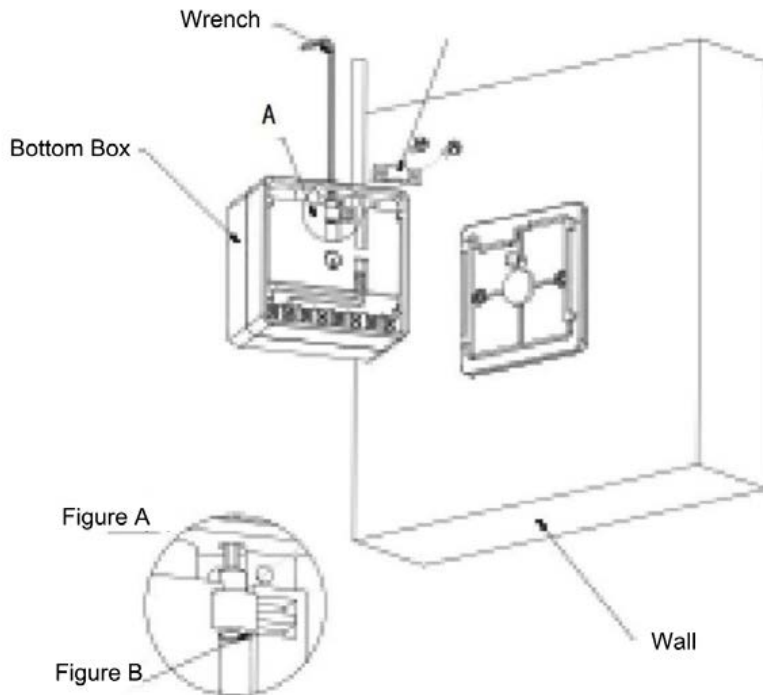

3. Push the differential pressure transmitter into position in the locking direction, and tighten the locking screw as shown in the diagram.

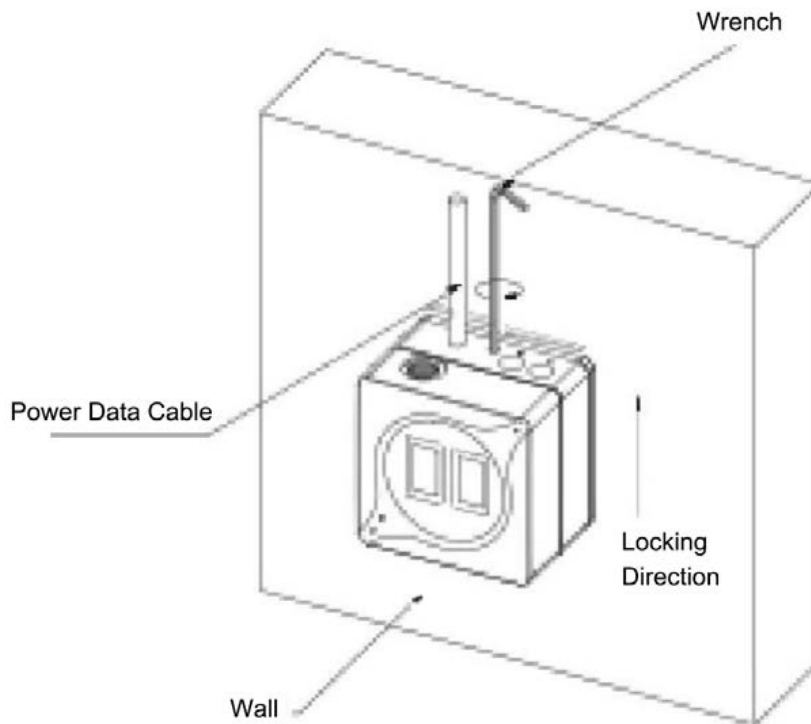

4. Connect the pressure-sampling tubes according to the markings on the differential pressure transmitter.

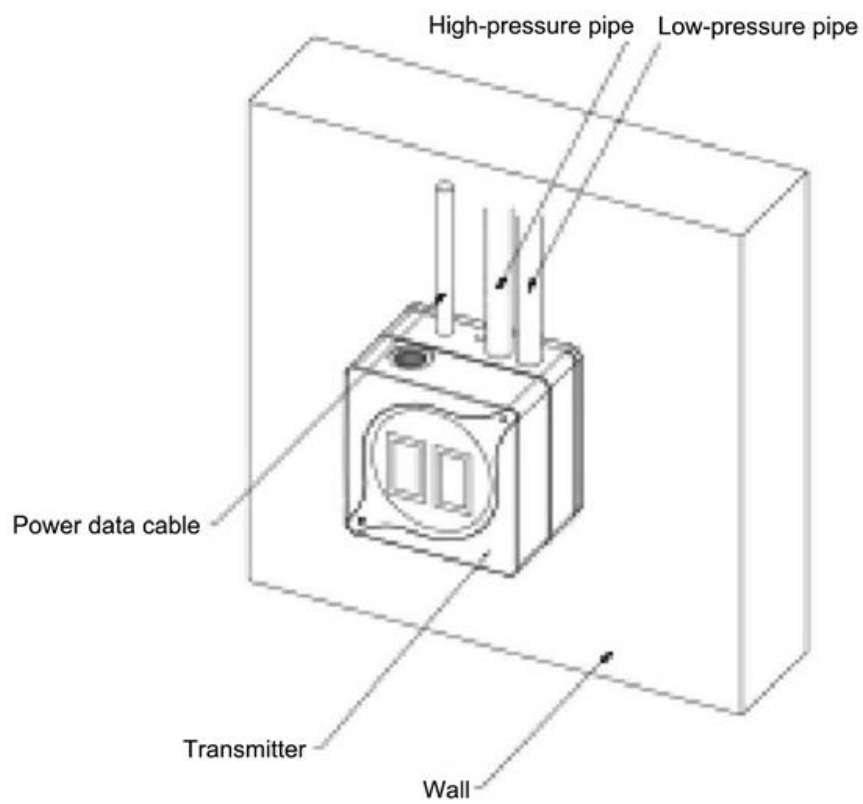

8. Unpacking Inspection

1. After pressurization, the pressure display or output shows no change or incorrect variation.
 - a. Check whether the gas sampling tube is blocked or kinked, and ensure the pipeline is free of obstructions or leakage.
 - b. Check whether zero calibration was performed under pressure. If so, re-zero calibration must be carried out in a zero-pressure environment.
 - c. Check whether pressure shock overload has caused damage to the transmitter. If damaged, return to the factory for repair.
 - d. Check whether the positive and negative pressure pipelines are connected correctly and match the current pressure conditions.
 - e. Check whether the current operating temperature exceeds the specified range; add a cooling device if necessary.
2. Pressure display is normal, but there is no analog output or the analog output is inaccurate.
 - a. Check whether the output wiring is correctly connected.
3. The screen display and readings fluctuate too fast or too slowly.
 - a. The sampling rate is too high or too low; please contact the manufacturer for customization.
4. Slight drift in zero pressure value.
 - a. Perform zero calibration after the air-conditioning or fan equipment is turned off.

Note:

1. Please ensure the device is used within the rated voltage range.
2. Do not allow pressure to exceed the pressure tolerance limit.
3. If the above troubleshooting methods cannot resolve the issue, please contact the manufacturer.