

1. Transducer Introduction and Wiring Diagram

1.1 Clamp on type transducer

- Introduction

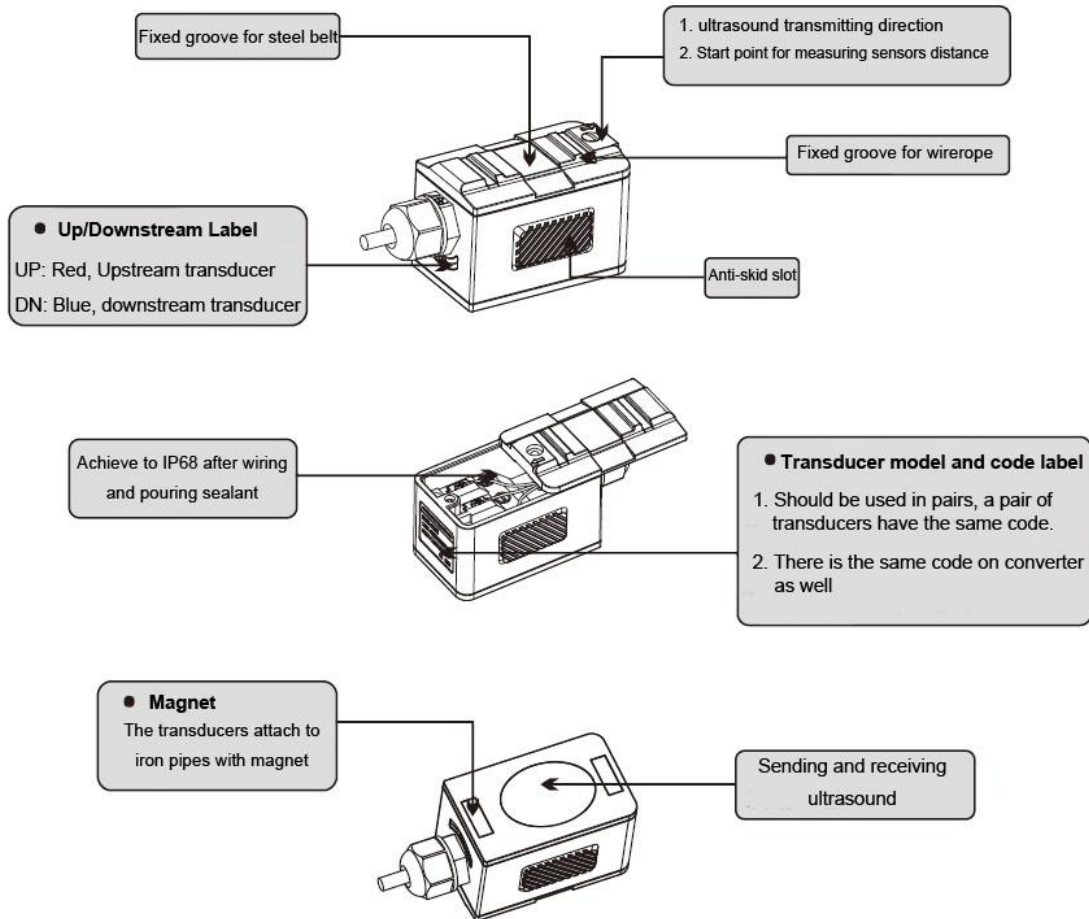

- Wiring Diagram

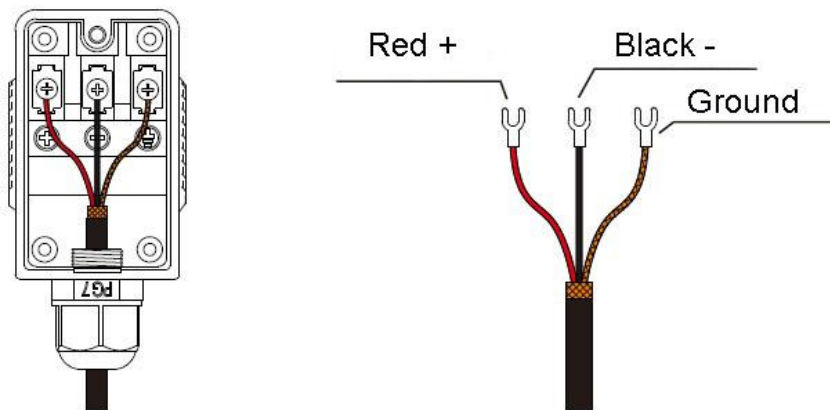

1.2 Insertion type transducer

- Introduction

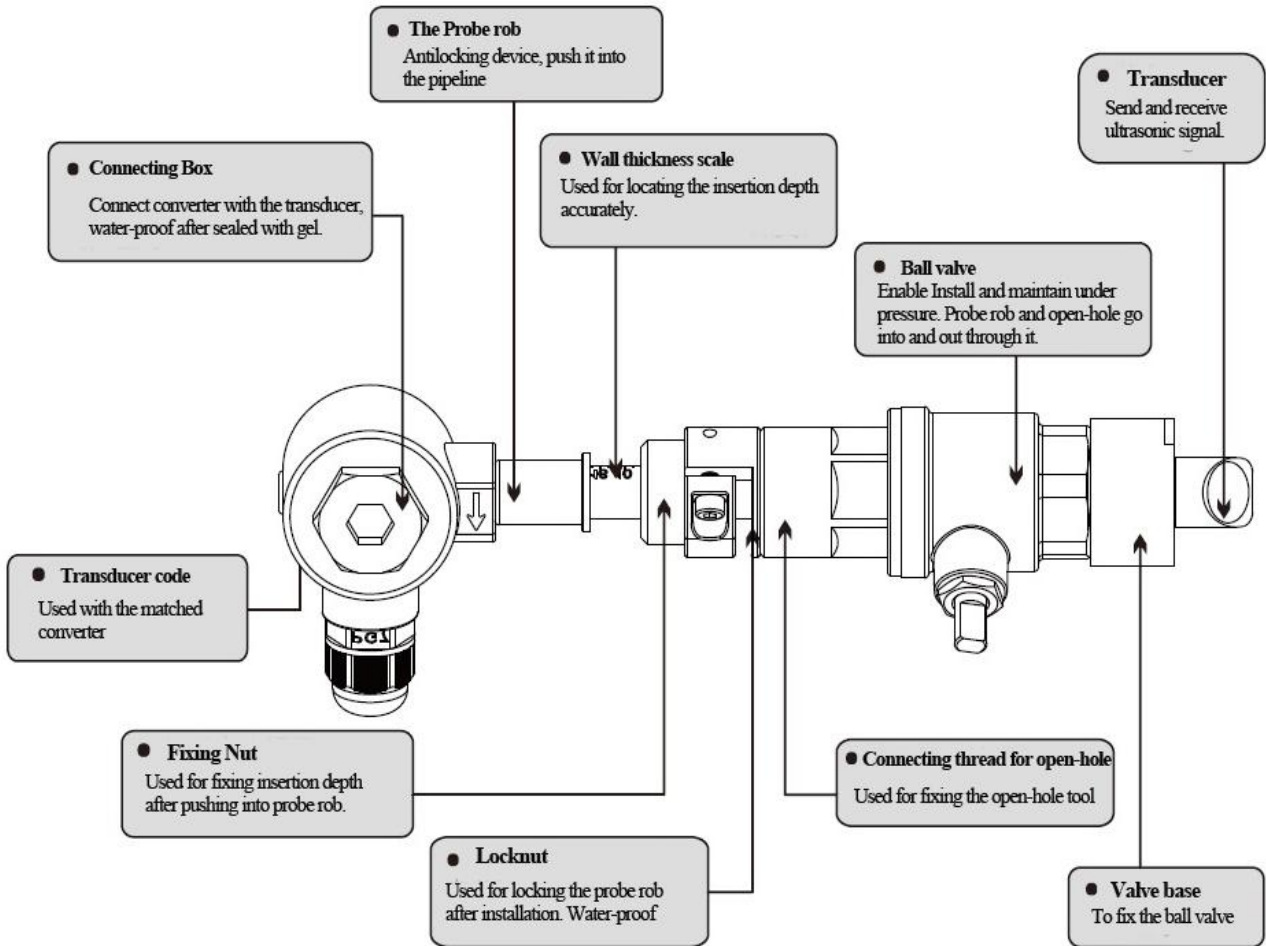

- Wiring Diagram

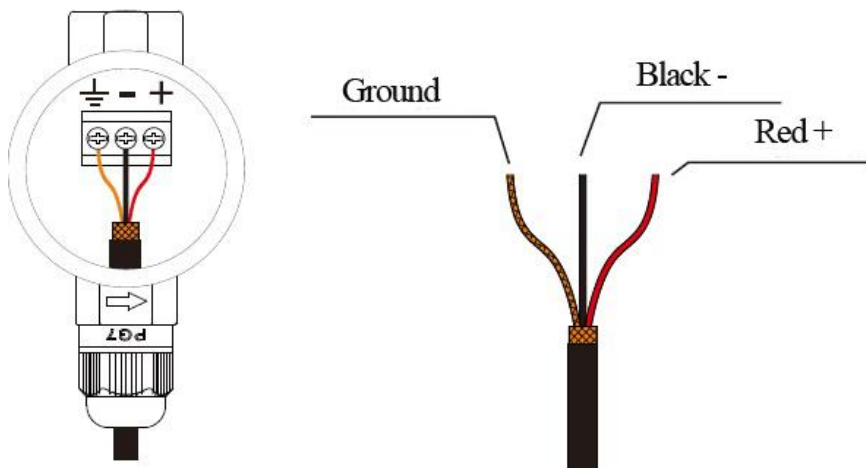

1.3 Inline type transducer

- Introduction

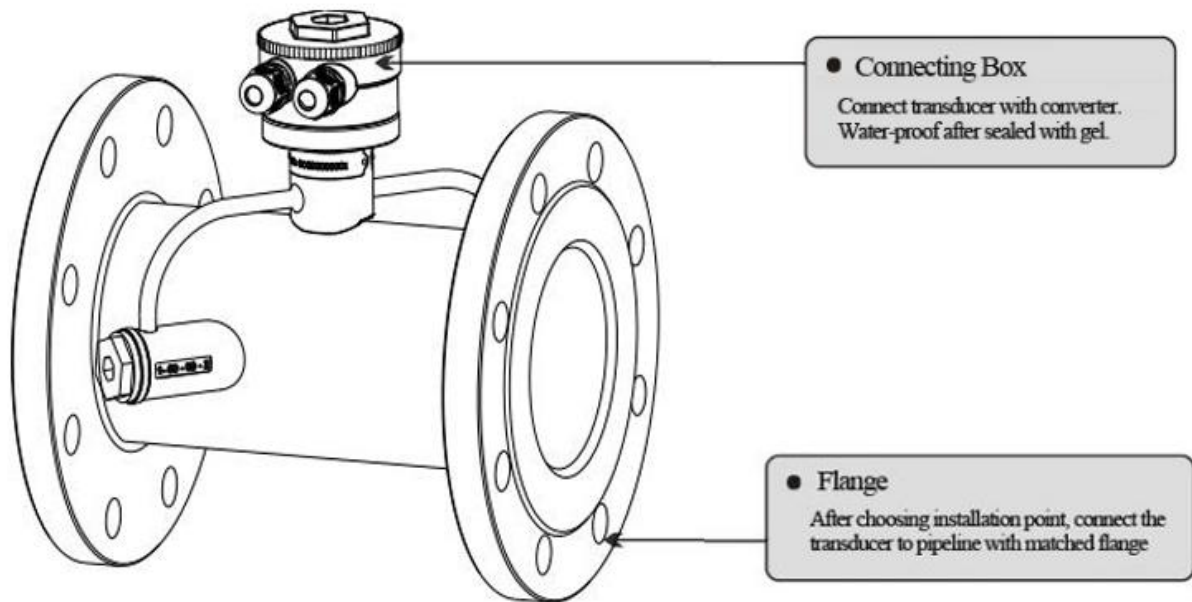

- Wiring Diagram

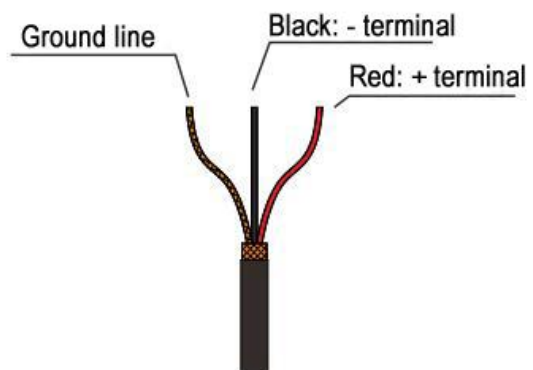
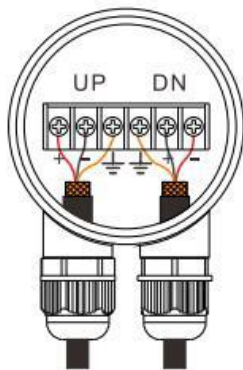

2. Display and Operation

2.1 Quick setup of measured parameters

Accurate measured parameters can have a great influence on measuring precision and reliability. It is suggested to measure the practical perimeter and wall thickness of the pipeline. Ultrasonic thickness gauge can be used to measure the pipe thickness.

Measured parameters setup is from Menu10 to Menu29. Please complete one by one.

>>> Following parameters need to be inputted before measurement:

1. Outer diameter unit: mm
2. Pipe thickness unit: mm
3. Pipe material
4. Lining parameters: thickness and sound velocity (If have lining)
5. Liquid type
6. transducer type
7. transducer mounting type

>> Above parameters setup generally follow the steps below:

1. Press keys **MENU 1 1** to enter M11 window to input the pipe outer diameter, and then press **ENT** key.
2. Press key **▼/-** to enter M12 window to input the pipe outer diameter and then press **ENT** key.
3. Press key **▼/-** to enter M14 window, and press **ENT** key to enter the option selection mode.
Use keys **▲/+** and **▼/-** to select the pipe material, and then press **ENT** key.
4. Press key **▼/-** to enter M16 window, press **ENT** key to enter the option selection mode. Use keys **▲/+** and **▼/-** to select the liner material, and then press ENT key. Select “No Liner”, if there is no liner.
5. Press key **▼/-** to enter M20 window, press **ENT** key to enter the option selection mode. Use keys **▲/+** and **▼/-** to select the proper liquid, and then press **ENT** key.
6. Press key **▼/-** to enter M23 window, press **ENT** key to enter the option selection mode. Use keys **▲/+** and **▼/-** to select the proper transducer type, and then press **ENT** key.
7. Press key **▼/-** to enter M24 window, press **ENT** key to enter the option selection mode. Use keys **▲/+** and **▼/-** to select the proper transducer mounting method, and then press **ENT** key.
8. Press key **▼/-** to enter M25 window and get the transducer installation distance.
9. Press **MENU 2 6** to store the parameters setup.

3. Transducers Installation

3.1 Choose installation points

Proper installation point is a key for transducer installation. Following factors must be considered: Full filled pipeline, shaking, steady flow, scaling, temperature, pressure, EMI, instrument well.

>> Full filled pipeline

Following situations can be full filled of liquid:

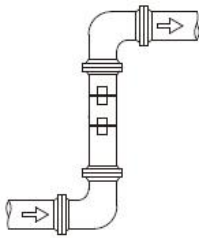

Vertical upward

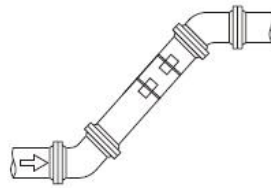

Obliquely upward

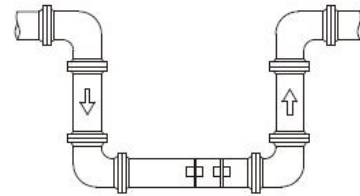

Lowest point

>> Shaking

There cannot be obvious shaking on the installation point, otherwise it needs to be tightened.

>> Steady flow

Steady flow is helpful for ensuring measurement accuracy.

Standard requests for steady flow are:

1. The pipe should be far away from pump outlet and half-open valve.
10D to upstream and 5D to downstream. (D means outer diameter)
2. 30D to pump outlet and half-open valve.

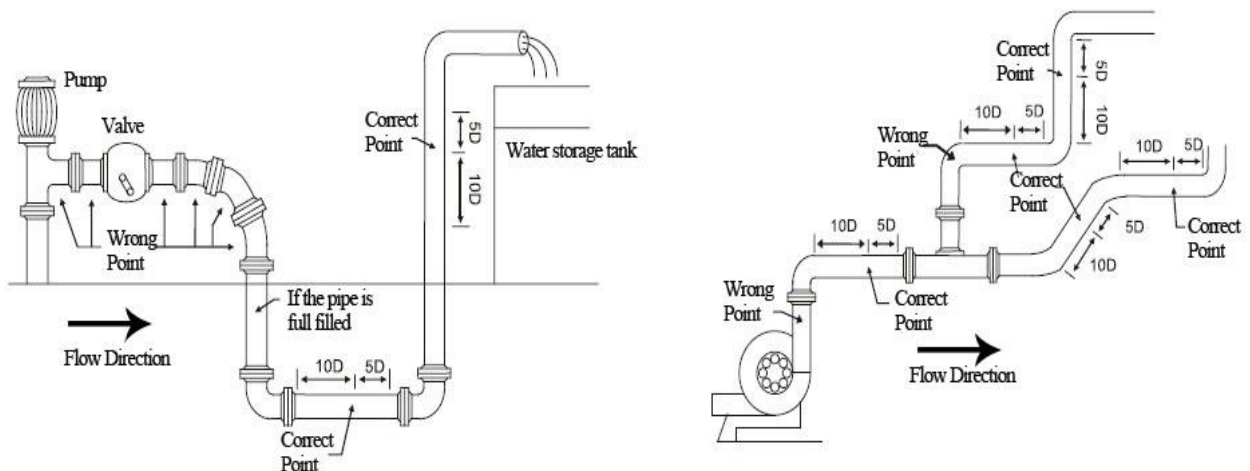

>> **Scaling**

The inside scaling would have bad effect on ultrasonic signal transmission, and would decrease the inner diameter as well. As a result, the measurement accuracy can not be guaranteed. Please try to avoid choosing the installation point with inside scaling.

>> **Temperature**

The liquid temperature on installation point should be in the working range of transducers. Please try to choose the point with lower temperature. Avoid to choose points like the outlet of boiler water and heat exchanger. Return water pipe would be better.

Temperature range of standard clamp on and insertion transducers: -30 ~ 90°C

Temperature range of high temperature clamp on and insertion transducers: -30 ~ 160°C

>> **Pressure**

The maximum pressure for standard insertion and inline transducer is **1.6MPa**

Out of this range need customized.

>> **EMI (electromagnetic interference)**

The ultrasonic flow meter, transducer and signal cable can be easily interfered by interference sources such as frequency changer, radio station, microwave station, GSM base station and high-tension cable. Please try to avoid these interference sources when choosing installation points.

The shield layer of flow meter, transducer and signal cable should be connected to earth.

Better to use isolated power supply. Do not use the same power supply with the frequency converter.

>> **Instrument well**

When measuring underground pipes or need to protect the measuring points, an instrument well is required. To ensure the enough installation space, the sizes of instrument well should meet the following requirements.

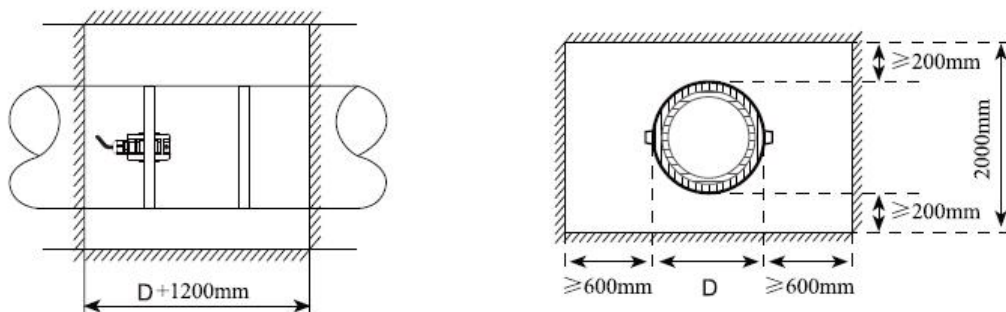

D means the pipe diameter

3.2 Clamp on transducer Installation

Before installation, please verify the parameters of pipeline and liquid. To ensure the installation accuracy.

1) Installation procedure

Select an installation method → Input the measuring parameters → Clean pipe surface → Install transducers → Check the installation

2) Select an installation method

There are two different methods for clamp on transducers: V method and Z method.

>> V method

V method should be priority selected for pipe sizes DN25 - DN200. Let the pair of transducers horizontal alignment, the central line in parallel with the pipeline axis.

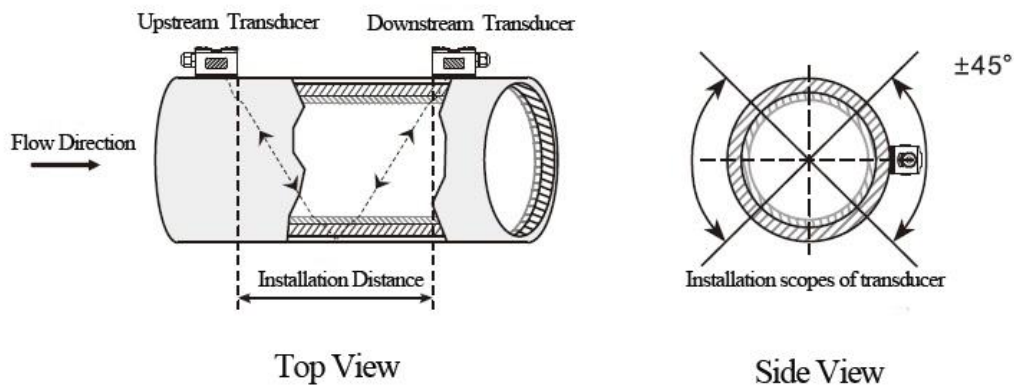

>> Z method

Z method should be priority selected for pipe sizes DN200 - DN6000. Also can be used when V method doesn't work well. Make sure the vertical distance of two transducers equals to the installation distance, and the two transducers are on the same axis surface.

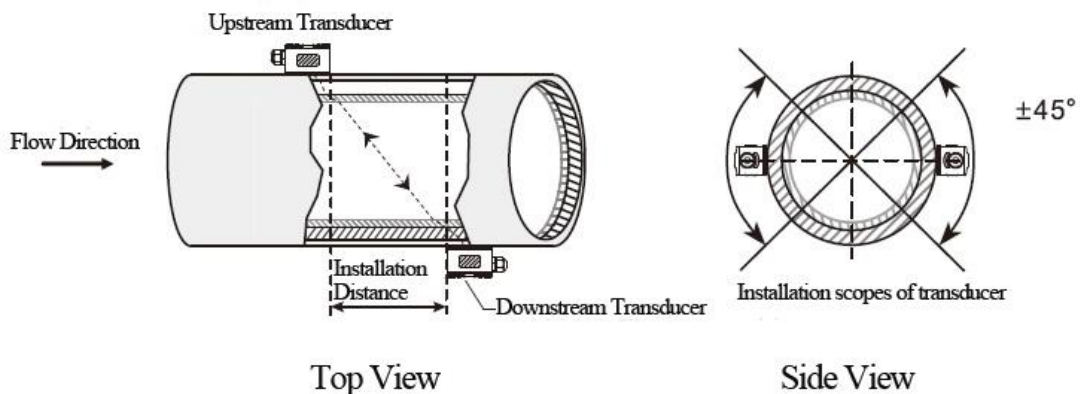

3) Positioning installation points

>> V method

The line between two transducers is parallel to pipe axis, and equal to the distance shown in the converter. As shown, A, B are the two installation points.

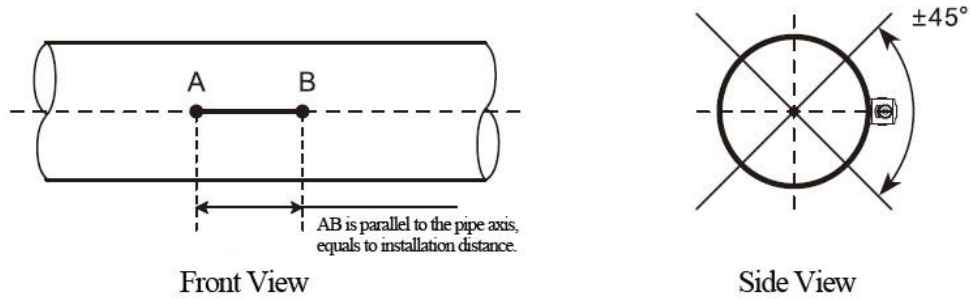

>> Z method

- ① Firstly according to the installation distance shown in converter, positioning two points A, C on the same side of pipeline. AC is parallel to pipe axis.
- ② Perpendicular to the pipe axis, opposite to point C, get Point B.
- ③ Check. Measure the length between A and B from both sides of the pipe, get AB_1 and AB_2 . If $AB_1 = AB_2$, then B is the correct point. If not, need to positioning point B and C again. As shown, A, B are the two installation points.

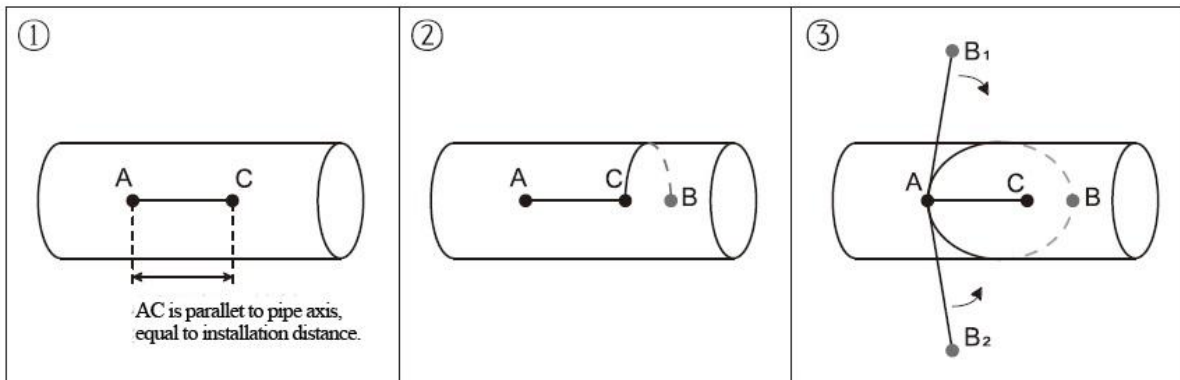

4) Clean the surface of installation points

Paint, rust and anti-corrosive coating on installation points need to be cleaned. It's good to use a polishing machine to get the metal luster.

As shown below:

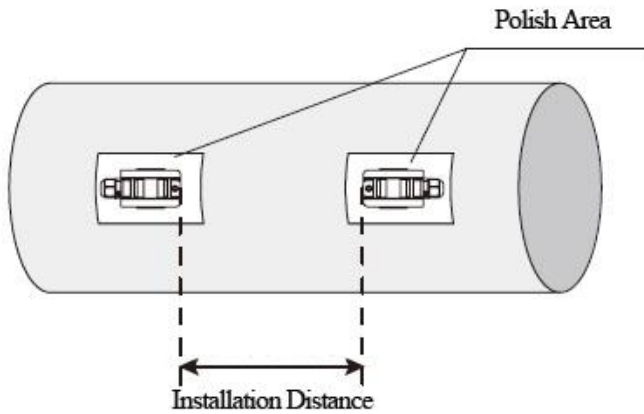

5) Install transducers

After transducer wiring and sealing, please evenly smear 2-3mm couplant on the transducer emitting surface. Then put the transducers on the installation points, fixed with steel belt or steel rope.

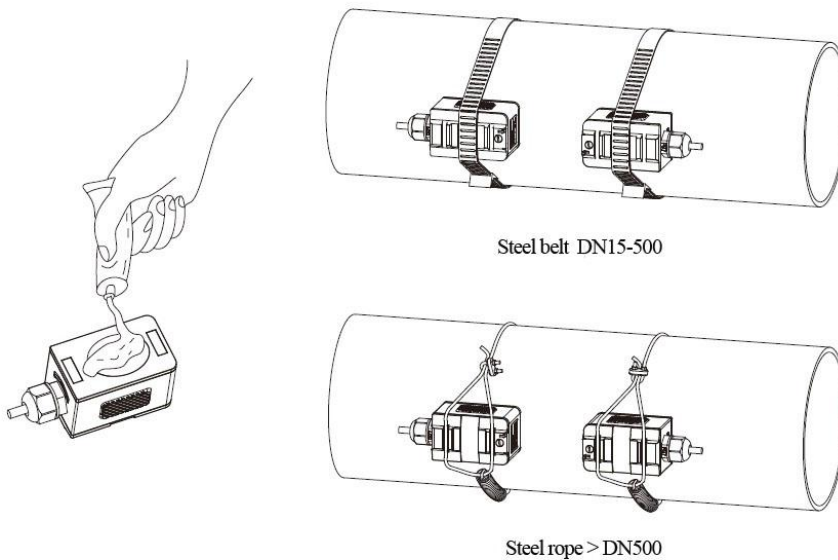

6) Check Installation

Please see details in Chapter 3.5

3.3 Insertion type transducer installation

 Before installation, please verify the parameters of pipeline and liquid. To ensure the installation accuracy.

1) Installation procedure

Select an installation method → Input the measuring parameters → Positioning installation points → Fix ball valve base → Open hole under pressure → Install transducers → Check the installation

2) Select installation method and positioning installation points

Insertion type transducers are suitable for pipe sizes > 50mm.

Two different installation methods: V method and Z method. Generally use Z method, only use V method for lack of space.

>> V method

V method can be used for DN50mm - 300mm. Let the pair of transducers horizontal alignment, the central line in parallel with the pipeline axis, and the transmit direction must be opposite.

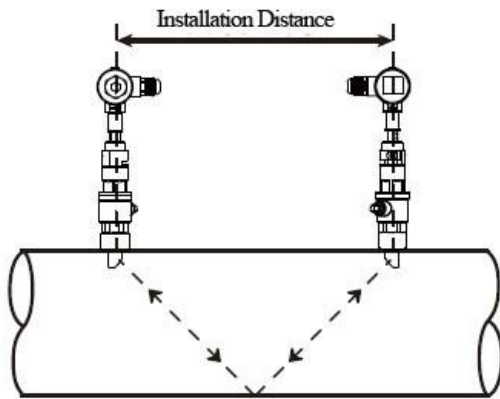

Top View

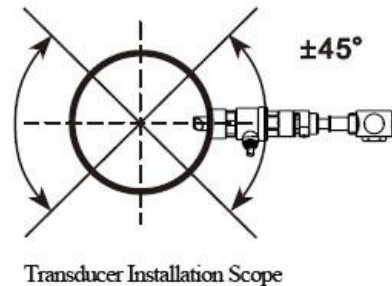

Side View

>> Z method

Z method can be used for all pipes > DN50mm. Make sure the vertical distance of two transducers equals to the installation distance, and the two transducers are on the same axis surface. The transmit direction must be opposite.

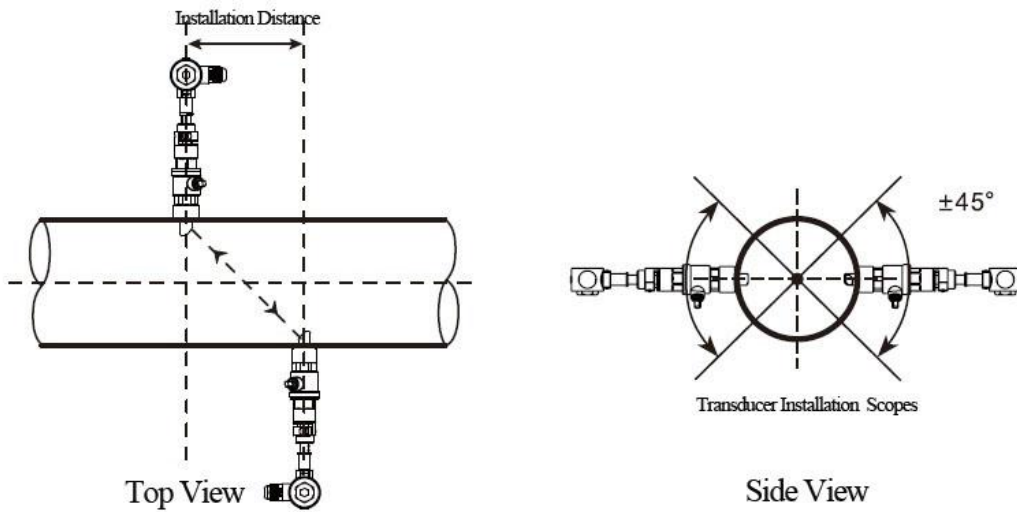

>> Parallel insertion

If there is insufficient installation space or the transducers can be only installed on the top of pipeline, parallel insertion transducer will be a good choice. (Pipe size ≥ 300)

Positioning of parallel insertion transducer need to meet the 3 factors as follow:

- Installation distance = Vertical distance of two transducers along the pipe axis direction
- Make sure two transducers are in the same horizontal line,
Insertion depth = $\frac{1}{3}$ inner diameter
- Users can set the distance between transducers by themselves. Recommend 300~500mm

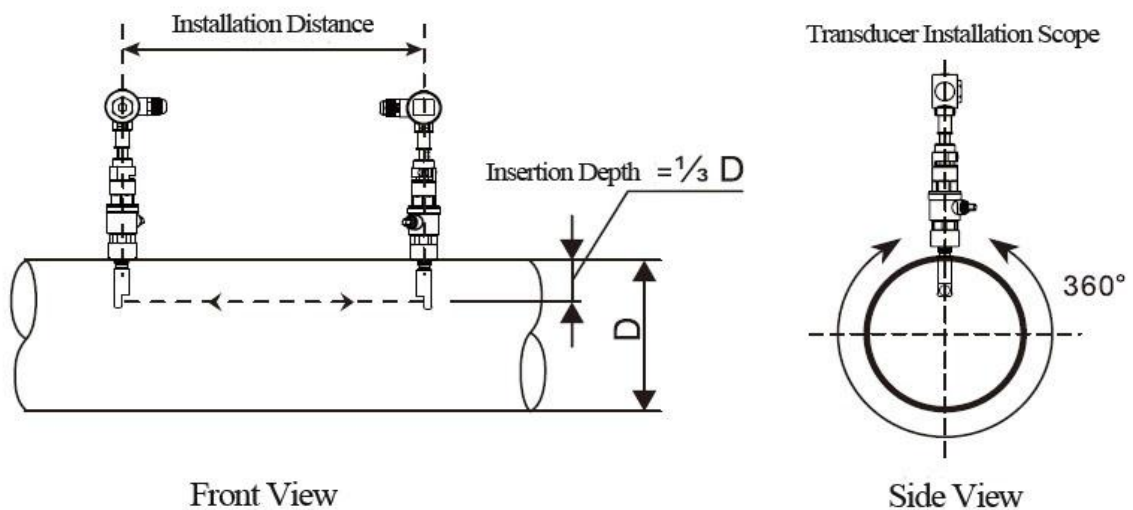

3) Positioning installation points

>> V method

The line between two transducers is parallel to pipe axis, and equal to the distance shown in the converter. As shown, A, B are the two installation points.

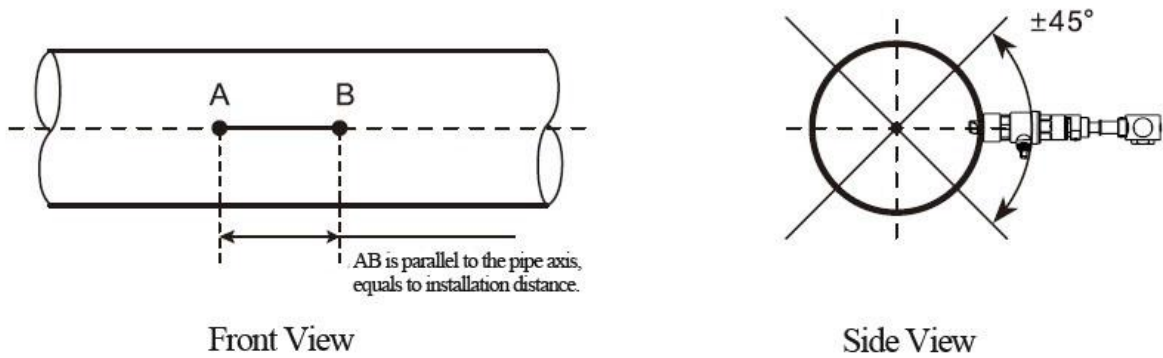

>> Z method

- ① Firstly according to the installation distance shown in converter, positioning two points A, C on the same side of pipeline. AC is parallel to pipe axis.
- ② Perpendicular to the pipe axis, opposite to point C, get Point B.
- ③ Check. Measure the length between A and B from both sides of the pipe, get AB_1 and AB_2 . If $AB_1 = AB_2$, then B is the correct point. If not, need to positioning point B and C again. As shown, A, B are the two installation points.

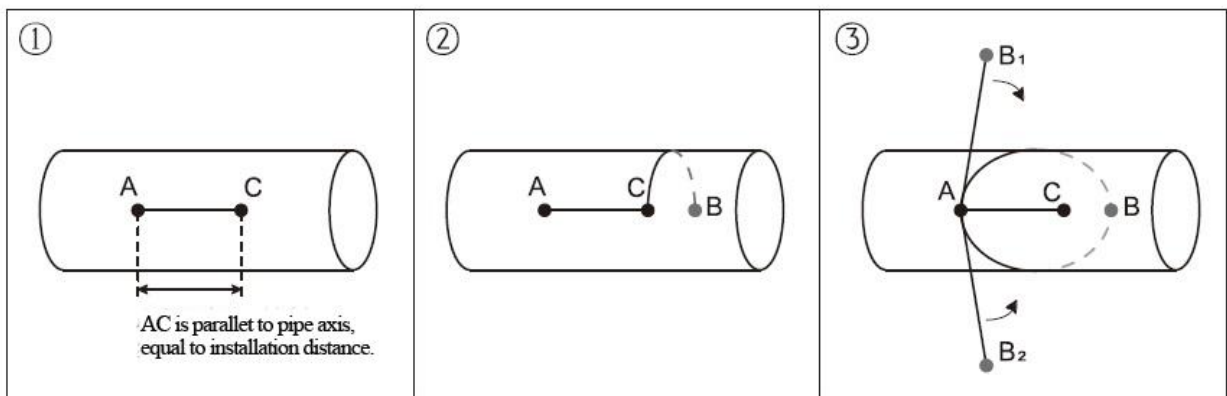

4) Fix ball valve base

>> Welding Fix

For carbon steel pipes, the ball valve base can be welded directly. Make sure that the central point of ball valve base is overlapped with the transducer installation point.

Matters need attention:

- Please take the PTFE sealing gasket out from the base before welding.
- Please clean the pipe surface around welding point before welding. Pay attention that there should not be any air hole during welding, which can avoid leaking. Welding strength must be ensured.
- Do not sputter welding slag on the base thread.
- Non-deformation of base during welding.

After welding, tighten ball valve into the base.

>> Pipe hoop Fix

For pipes can't be welded directly like cast iron pipe, cement pipe, copper pipe and composite pipe, customized pipe hoop is recommended.

The hoop center should be overlapped with the transducer installation point. Please compress the sealing gasket tightly to avoid leaking.

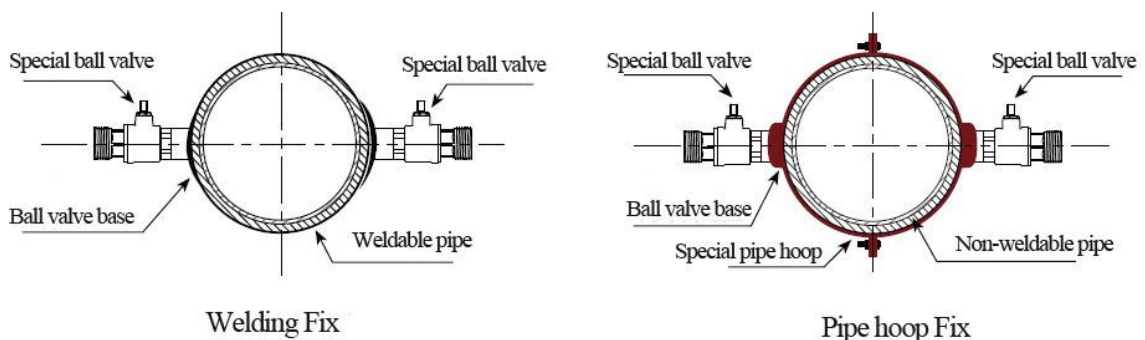

5) Open hole

After finishing the installation of ball valve and base, insert the open-hole tool into ball valve and lock it. Then open the ball valve, start drilling, from slow to fast. Close ball valve after drilling.

See more details in the video of insertion transducer installation.

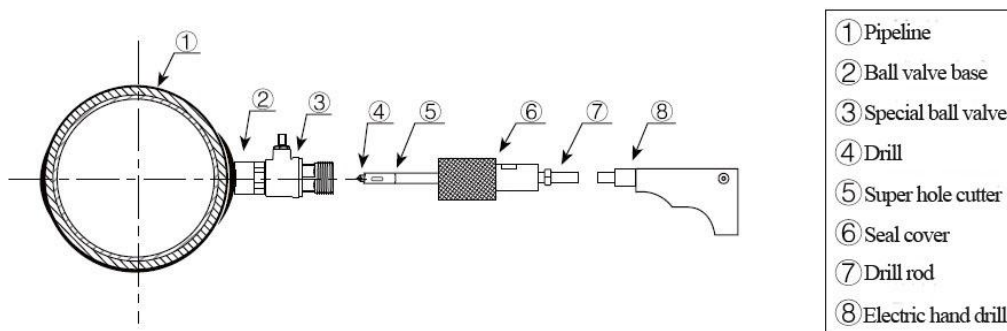

6) Install transducer and adjustment

Adjust the proper insertion depth and transmit direction to get good ultrasound signal.

>> Insertion depth adjustment

Adjust the depth scale according to pipe wall thickness, and completely push in the transducer rod.

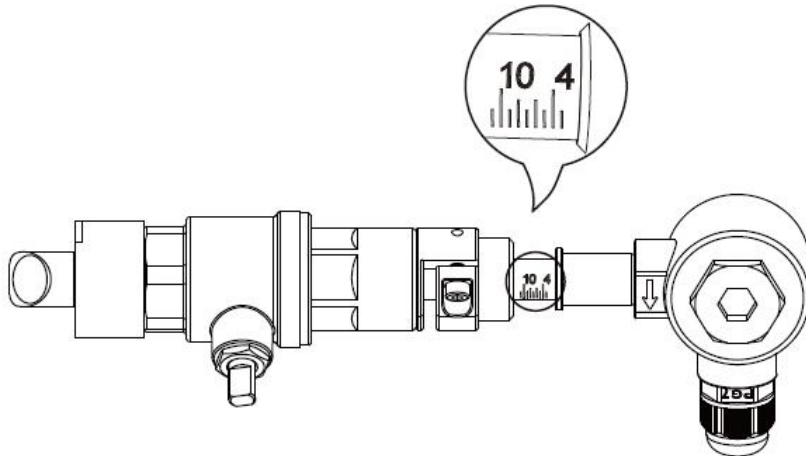

>> Transmit direction

There is a indicating arrow on the transducer junction box, the arrow direction on two transducers should be opposite “ $\rightarrow \leftarrow$ ” and parallel to the pipe axis.

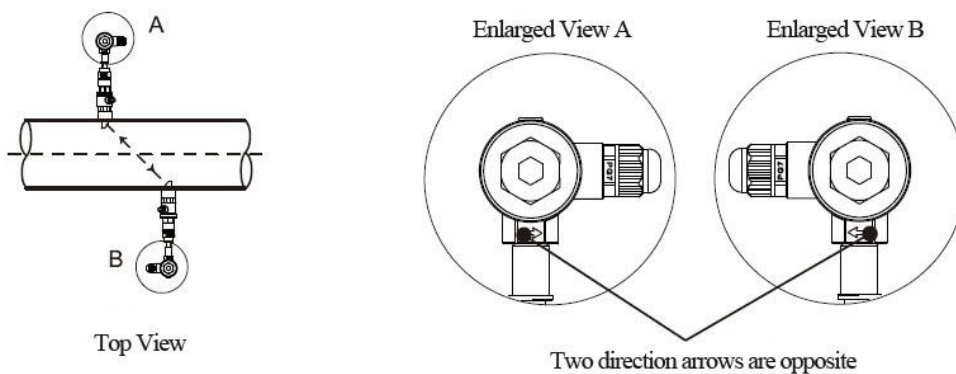

>>Operation steps

- Tighten the locknut into ball valve, adjust the insertion depth scale.
- Open ball valve, completely push in the upstream transducer rod. Adjust the transmit direction parallel with pipe axis, and point to the installation point of downstream transducer. Lock it after adjustment.
- Install downstream transducer in the same way. Adjust the transmit direction to get the best signal strength and watching Menu91, if the value is between 97% ~ 103%, the installation is correct. If not, need to re-adjust the insertion depth and transmit direction until meet the requirement.





7) Check installation

Please see details in Chapter 3.5

3.4 In-line type transducer installation

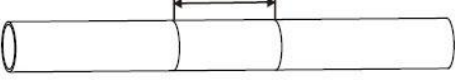
After choosing the installation point, install the transducer in the pipeline with companion flanges. Then connect the transducer to converter with special signal cable. Installation is complete.

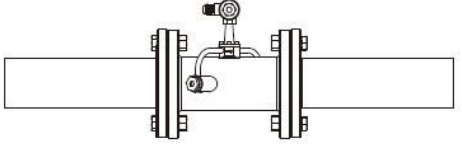
1 Installation method

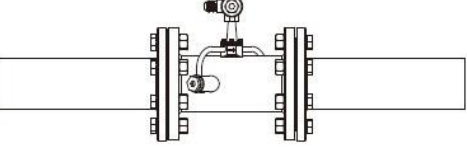
<p>① Confirm installation size</p> <p>Length of transducer L + 2×thickness of seal gasket + 10mm</p> 	<p>② Cutting pipeline</p> 
<p>③ Equip companion flanges</p> 	<p>④ Positioning the flanges</p>  <p>Twist 3 screws and averagely positioning the flanges. Fixing with spot welding.</p>
<p>⑤ Welding the flanges</p>  <p>Remove the inline transducer and full-length welding flanges.</p>	<p>⑥ As the flanges cooled, put in the seal gasket and tighten the screws. Then connect to converter with signal cable</p> 

2) Check installation

Please see details in Chapter 3.5

3.5 Check Installation

The flow meter includes the detection ability. M90 is used for checking signal strength and quality. M91 is used for checking the ratio of measured and theoretical transmission time (transmission time ratio).

1) Check signal strength and quality

M90 is used for checking the signal strength and signal quality(Q value) of upstream and downstream transducers.

Signal strength is represented by numbers 00.0 ~ 99.9, 00.0 means no signal and 99.0 means maximum signal. Generally, the flow meter can work properly when signal strength is > 60.0

Signal quality (Q value) is represented by numbers 00 ~ 99. 00 means signal is worst and 99 means signal is best. The flow meter can work properly when Q > 60.

During the installation, please adjust the transducer to make the signal strength and signal quality the larger the better. This will ensure the flow meter long term stable operation and lead to accurate measurement.

Signal strength and Q value	Installation Judgement
< 60	Can not work
60~75	Bad
75~80	Good
>80	Excellent

2) Check transmission time ratio

M91 is used for displaying transmission time ratio. It is a percentage ratio between theoretical transmission time and measured transmission time. It shows the relation between setting parameters and actual transducer installation distance. This ratio should be between 97% ~ 103%. If not in the range of 97%~103%, it means that the parameters and transducer installation distance are inconsistent. Please check separately.

4. Finish Installation

1) Commonly used menus. M00 or M02 is for meter reading. M30~M33 is for unit selection. M40 is for selecting damping factor, generally 5~10 sec. M60 is for correcting time and date. M26 is for curing parameters.

2) To avoid signal reduction and improve anti-jamming ability, it is better to use the customized signal cable from flow meter manufacturer.

3) The length of cables between converter and transducer should be as short as possible, cannot exceed 200m.

4) The temperature and humidity of working environment should be in the range of technical specifications. Avoid direct sunlight on LCD.